Thyristor power controller

TE10A

**Burst-firing
Single-cycle
Advanced Single-cycle**

**Control of short-wave infrared elements and loads
of constant resistance up to 20kW**

User Manual

©Copyright Eurotherm Automation 1996

All rights reserved. All reproduction or transmission in any form or using any procedure, without written authorisation from EURO THERM AUTOMATION, is strictly prohibited.

TE10A

Industrial thyristor power controller

Burst-firing, Single-cycle or advanced Single-cycle

CONTENTS

SAFETY DURING INSTALLATION AND USE	3
EUROPEAN DIRECTIVES	4
TECHNICAL SPECIFICATION	6
PRODUCT CODE	8
FUSES	8
CURRENT DERATING (as a function of ambient temperature)	8
INSTALLATION AND DIMENSIONAL DETAILS	9
FRONT FACIA	10
TERMINALS AND CONNECTORS	11
WIRING	12
Control of TE10A by temperature controller	12
Local control by potentiometer	13
Local control by contacts	13
Auxiliary power supply (option)	14
INPUT SIGNAL	15
FIRING MODES	16
Burst firing	16
Single-cycle	17
Advanced Single-cycle	18
CONFIGURATION OF FIRING MODE	19
Burst firing and standard Single-cycle (codes FC and FC1) ..	19
Advanced Single-cycle (code SCA)	20

For any further information, or if in doubt, please contact Eurotherm Controls where qualified staff are available to advise or assist you with the commissioning of your installation.

SAFETY DURING INSTALLATION AND USE



This symbol means that failure to take note of the information given in this manual may have serious consequences for the safety of personnel and may even result in electrocution.

DANGER!

- Units must be installed in fan-cooled electrical cabinets to ensure that condensation and pollution are excluded. The cabinet must be closed and bonded to the safety earth in accordance with Standards NFC15-100, IEC 364 or current national Standards. It is the responsibility of the user to install and wire the installation in accordance with current professional practice.
- Before any connection or disconnection, make sure that power and control cables and leads are isolated from voltage sources.
- The safety earth must be connected before any other connection is made during wiring and should be the last cable to be disconnected.
- Thyristors are not isolating devices.

The high-speed fuse recommended is used only to protect the thyristors: under no circumstances can it be used to protect the installation. For this reason it is very important to fit a suitable device guaranteeing protection for, and electrical isolation of, the installation in compliance with current practice.

- Access to the internal components of the product is prohibited to users. Disconnect the **TE10A** completely before dismantling.
- The temperature of the heatsink fins may exceed 100°C. Avoid all contact, even occasional, with the heatsink while the **TE10A** is operational. The heatsink remains hot for approximately 15mins after the **TE10A** has been switched off.

EUROPEAN DIRECTIVES

CE MARKING

TE10A products carry the CE mark in compliance with the essential requirements of the Low Voltage Directive 73/23EC of 19/2/73 (amended by the Directive 93/68/EC of 22/7/93).

For safety reasons, **TE10A** products installed and used in compliance with this user manual meet the essential requirements of the European Directives mentioned above.

CE DECLARATION OF CONFORMITY

A CE Declaration of conformity is available on request.

ELECTROMAGNETIC COMPATIBILITY (EMC)

(For an industrial environment only, must not be used in domestic environments)

Eurotherm certifies that **TE10A** Burst firing and Single Cycle fired products, installed and used in compliance with their manual, meet the following EMC standards and enable the system which incorporates them to comply with the EMC Directive as far as those **TE10A** products are concerned.

EMC STANDARDS

Immunity	Generic standard: EN 50082-2
	Test standards : EN 61000-4-2, EN 61000-4-4, EN 61000-4-5 ENV 50140, ENV 50141, ENV 50204
Emission	Generic standard: EN 50081-2
	Test standard : EN 55011
	Product standard: IEC 1800-3

INTERNAL EMC FILTER

An EMC filter is incorporated into the Burst firing and Single Cycle firing **TE10A** to reduce conducted emission in accordance with the EMC Directive.

VALIDATION BY INDEPENDENT BODY

Eurotherm has validated the compliance of these **TE10A** controllers with the Low Voltage Directive mentioned above and with EMC standards through product design and laboratory testing.

The controls carried out on **TE10A** products are listed in a Technical Construction File validated by the **LCIE** (Central Laboratory for the Electrical Industries), a Recognised Competent Body.

PRECAUTIONS

Before installation, please read this manual thoroughly.

Eurotherm cannot be held responsible for any damage to persons or property, or for any financial loss or costs arising from incorrect use of the product or failure to observe the instructions given in this manual.

PERSONNEL

The installation, configuration, commissioning and maintenance of the power unit should only be carried out by personnel **qualified and trained** to work with low voltage electrical equipment in an industrial environment.

INDEPENDENT SAFETY DEVICE

Given the value of the equipment controlled by **TE10A**, it is the responsibility of the user, and it is highly recommended, that an independent safety device (alarm) should be installed. This alarm must be tested regularly. Eurotherm can supply suitable equipment.

'ELECTROMAGNETIC COMPATIBILITY' INSTALLATION GUIDE

In order to help you reduce the effects of electromagnetic interference depending on the product installation, Eurotherm can supply you with the 'Electromagnetic Compatibility' Installation Guide (ref. HA025464).

TECHNICAL SPECIFICATION

Power

Nominal current at 45°C	16, 25 or 40A.
Nominal voltage	100Vac to 500Vac +10%, -15%
Supply frequency	50 or 60Hz (nominal) ± 2 Hz
Current in 'off state'	Below 30mA typically

Regulation

Type of regulation	The load power is proportional to the control input
Linearity	Better than $\pm 2\%$ of the full range
Stability	Automatic compensation for supply variations from $\pm 10\%$ of the nominal voltage. Stability better than $\pm 2\%$ of the full range on constant resistance
Firing modes	Thyristor firing at zero voltage <ul style="list-style-type: none">• Burst mode: firing and non-firing over a whole number of mains cycles• Single-cycle: firing or non-firing for one mains cycle• Advanced Single-cycle: firing over a whole number of mains cycles, non-firing over a whole number of half cycles
Firing indicator	Green LED on front facia

Control Inputs

External signal type	Analogue, DC voltage or current: 0 - 5V, 0 - 10V or 4 - 20mA
Input impedance	Voltage 100K Ω , current 250 Ω
Local control	External potentiometer 10k 'Dry' contact: logic operation - 'all or nothing' A '5V user' voltage is available

CE marking

Electrical safety	The CE Mark in accordance with the Low Voltage Directive 73/23/EC amended by the Directive 93/68/EC of 22/7/93
-------------------	--

EMC	These TE10A products comply with Electromagnetic Compatibility test standards (see page 4)
Environment	
Operating temperature	0 to 60°C, (see derating curves) at maximum altitude of 2000m Storage: -10 to +70°C
Operating atmosphere	Non-conductive, non-explosive and non-corrosive
Humidity	RH: 5 to 95%, non-condensing
Pollution	Pollution degree 2 permissible (IEC 664)
Thyristor protection	External fuse, internal MOV (varistor) and RC snubber
Protection degree	IP20 (in accordance with IEC 529; ¶11.4, table 5)
Insulation (1 minute test)	Isolation distances according to IEC 664 2000Vac between power and earth 3600Vac between power and control inputs
Cooling	Natural convection
Mounting	Vertical on DIN rail
Option	
Auxiliary power supply	115Vac or 230Vac used in the case of non-standard mains or if independent power supply required
Wiring	The separate auxiliary power supply must be in phase or anti-phase with the load supply
Guarantee	Two years for parts and labour (return to factory)

In order to maintain its 'leading edge' Eurotherm may have to make changes to its specifications without advance notice. For any further information, or if in doubt, please contact Eurotherm Controls.

PRODUCT CODE

Model	Current	Voltage	Input	Firing	Option	00
TE10A	16A 25A 40A	100V 115V 200V 230V 240V 277V 380V 400V	415V 440V 480V 500V	0V5 0V10 4mA20	Single-cycle: FC1 Advanced Single-cycle: SCA* Burst-firing: FC	Separate power Supply 115V 230V

* SCA mode uses different firing board

THYRISTOR PROTECTION FUSES

(Thyristor protection except for short-wave infrared application)

Current	Rating	Code (Fuse & fuse-holder)	Dimensions (mm)
16A	20A	FU1038 / 16A / 00	81 x 17.5 x 68
25A	32A	FU1038 / 25A / 00	81 x 17.5 x 68
40A	50A	FU1451 / 40A / 00	95 x 26 x 86

CURRENT DERATING (as a function of ambient temperature)

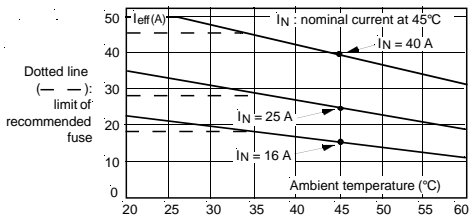

INSTALLATION AND DIMENSIONAL DETAILS

Minimum spacing between 2 TE10A units:

10mm up to 4

17.5mm over

Dimensions
(in mm)

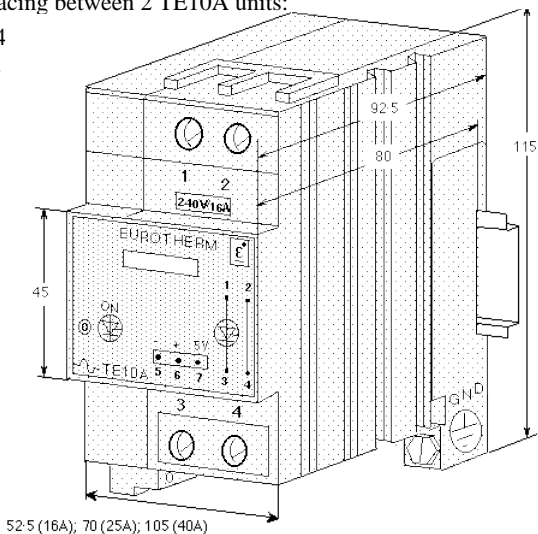

DIN rail clip mounting

(EN 50022-35 x 7.5 and 35 x 15)

Ground continuity: For reasons of electromagnetic compatibility ensure that the metal DIN rail of the **TE10A** installation is electrically bonded to the reference ground (panel or bulkhead).

FRONT FACIA

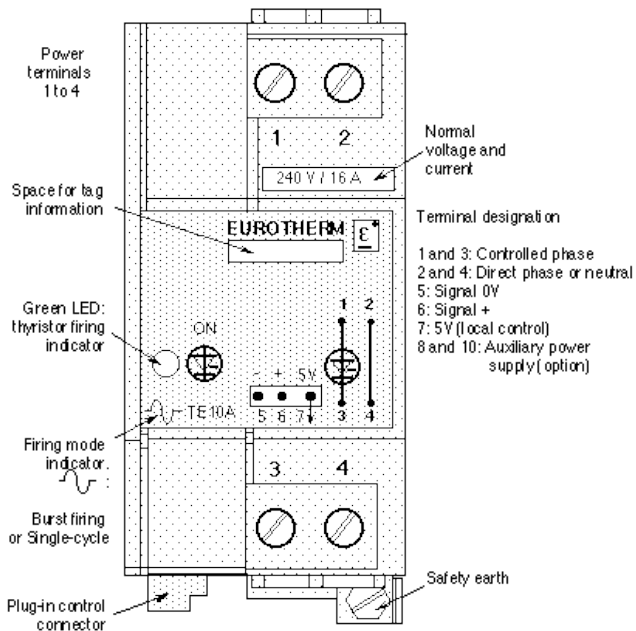

TERMINALS AND CONNECTORS

Power terminal block: cage terminals for 1.5 to 16mm² cables, strip insulation by 16 mm, tightening torque 1.2 Nm.

Safety earth wiring: same section as power conductor, tightening torque 2 Nm.

Control connection to terminals 5 & 6, and separate auxiliary power supply connection (option) to terminals 8 & 10: use 0.5 to 1.5 mm² wire, strip insulation by 7 mm, tightening torque 0.4 Nm (0.25 Nm for terminals 8 & 10).

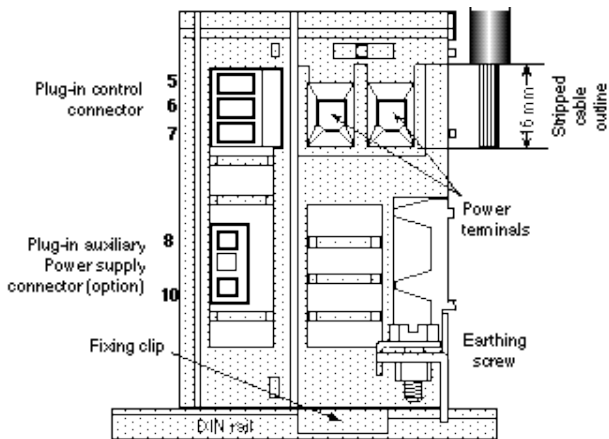

View from below

WIRING

Control of TE10A by temperature controller

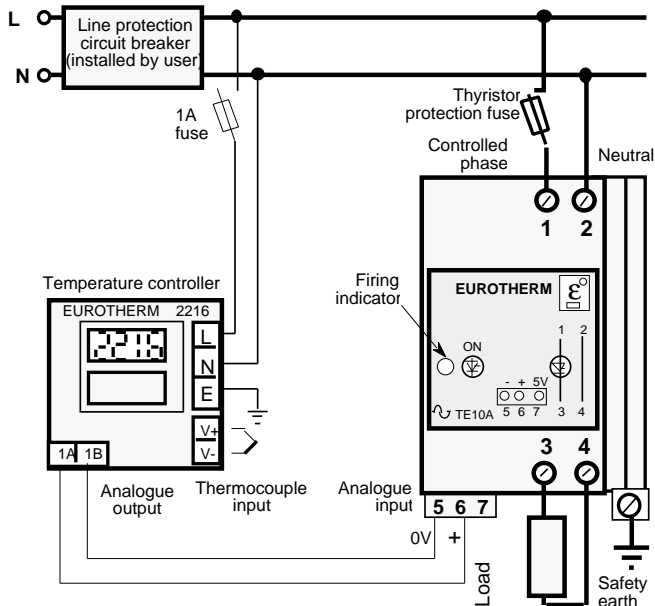

Example of wiring for **TE10A** (240V nominal, input 0 to 10V) controlled by Eurotherm 2000 series temperature controller.

Local control by potentiometer

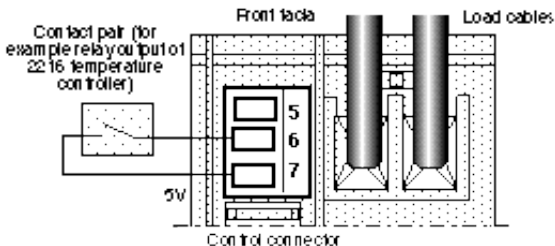

The input must be configured as **0 to 5V** (code 0V5).

Local control by contacts

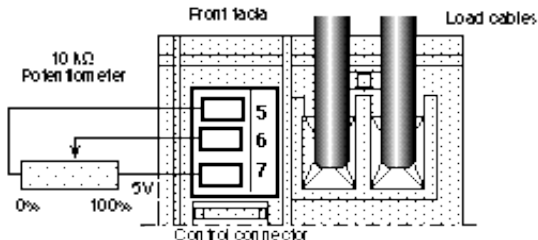

The input must be configured as **0 to 5V** (code 0V5).

Auxiliary power supply (option)

Use of **TE10A** with non-standard mains.

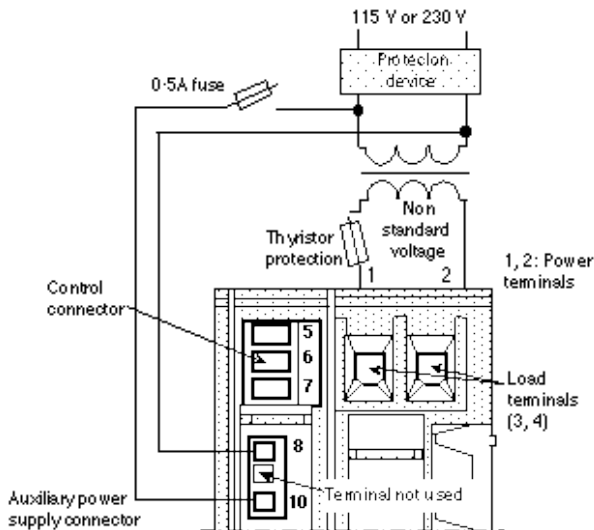

Example of separate auxiliary power supply wiring (option).

The auxiliary power supply must be **in phase or in anti-phase** with the load supply.

INPUT SIGNAL

External control

The **TE10A** is controlled by a DC analogue signal.
Signal type: voltage (0 to 5V or 0 to 10V) or current (4 to 20mA).
Input impedance: in voltage: 100k; in current: 250 ohms.

Local control

Local control is possible using a 10k potentiometer (analogue operation) or via 'dry' contacts (logic operation).
A '5V User' voltage output (terminal 7) is provided for these control modes (see wiring diagrams, page 13).
The input must be configured for 0 to 5V (0V5) for local control.

Input configuration (see pages 19 and 20 for Firing configuration)

The signal type (voltage or current) and the signal level are configured in the factory by the 'Coffee beans' located on the circuit board (see pages 19 and 20).

The following table enables the user to check the configuration or to re-configure the **TE10A** if required. In this table, the **x** denotes the corresponding solder link ('Coffee bean').

Signal type	Solder links ('Coffee beans')		
	GR1	GR2	GR5
0 - 10V			
0 - 5V		x	
4 - 20mA	x	x	x
Local control		x	

FIRING MODES

Three firing modes are possible:

Burst firing, Single-cycle and advanced Single-cycle.

Thyristor firing and quenching occurs at **zero voltage** which minimises interference to the supply network.

Burst firing

Burst firing mode consists of supplying a series of **whole mains cycles** to the load.

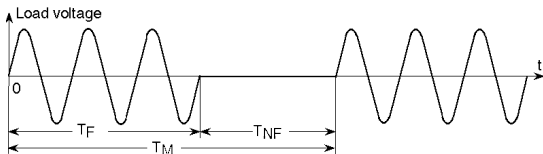

The load power is proportional to the ratio of the firing time (T_F) to the modulation time (T_M). The OFF time (T_{NF}) is also a series of whole mains cycles.

$$T_M = T_F + T_{NF}$$

The period of modulation is **variable** according to the output power demand.

- At 50% of nominal power the thyristors are on for $300\text{ms} \pm 100\text{ms}$ and are off for $300\text{ms} \pm 100\text{ms}$ (at 50 Hz)
- For a setpoint less than 50%, the **non-firing** period **increases**, and the firing period is fixed ($300\text{ms} \pm 100\text{ms}$)
- For a setpoint greater than 50%, the **firing** period **increases**, and it is the non-firing period which is fixed ($300\text{ms} \pm 100\text{ms}$)

Single-cycle

The mode of firing with only one firing or non-firing mains cycle is called **Single-cycle**.

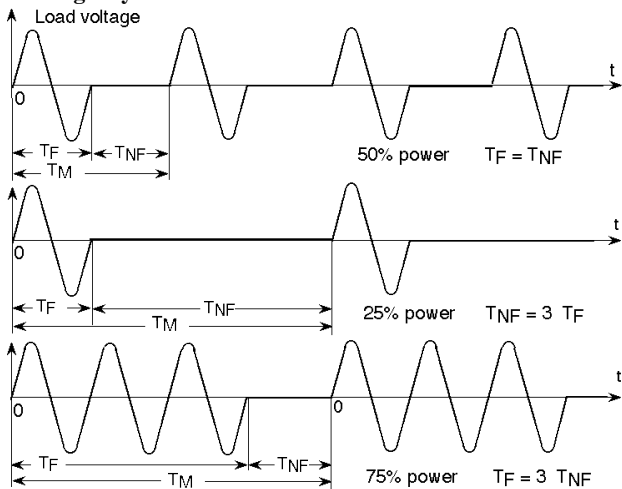

- At 50% of nominal power the thyristors are on for 20ms and are off for 20ms (at 50Hz)
- For a setpoint less than 50% the non-firing period increases and the **firing** period is **fixed** at 20ms
- For a setpoint greater than 50% the firing period increases and it is the **non-firing** period which is **fixed** at 20ms.

Advanced Single-cycle (Uses different board)

In order to minimise power fluctuation during the modulation period, the advanced Single-cycle mode uses half-cycles for non-firing.

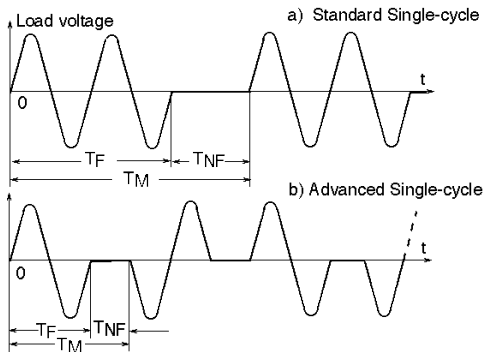

Examples of firing in Single-cycle (a) and in advanced Single-cycle (b) modes at 66.6% of nominal power.

- For a setpoint less than 50%, firing is effected on mains half-cycles. The firing time is fixed at one cycle (20ms at 50Hz)
- For a setpoint greater than 50%, **non-firing** is reduced to **one half-cycle**. Firing is effected over whole cycles.

The use of half-cycles for non-firing is the reason for the reduction in flicker and brightness of infrared elements compared with Single-cycle.

CONFIGURATION OF FIRING MODE

(see page 15 for Input configuration)

The thyristor firing mode is configured by means of the 'Coffee beans' located on the circuit board.

According to the firing mode, the TE10A is fitted with one of two boards:

- Board Type 1: Burst-firing or Single-cycle mode
- Board Type 2: Advanced Single-cycle mode

Burst firing and Single-cycle (codes FC and FC1)

In **Burst-firing** mode, 'Coffee beans' **GR4** and **GR6** are soldered.
In **Single-cycle** mode 'Coffee beans' **GR4** and **GR6** are **not** soldered.

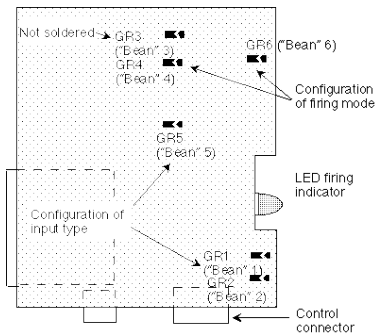

Board Type 1

Positioning of 'Coffee beans' on board Type 1 (solder-side view)

Advanced Single-cycle (code SCA)

Board Type 2, which provides advanced Single-cycle firing, is not re-configurable as far as the firing mode is concerned.

The information given below is intended for checking, if necessary, the configuration of the thyristor firing mode and input type, or for a possible change of input type.

In **advanced Single-cycle mode**, 'Coffee bean' **GR8** must be **soldered**

'Coffee beans' **GR3, GR4, GR6, GR7 & GR9** must **not** be soldered

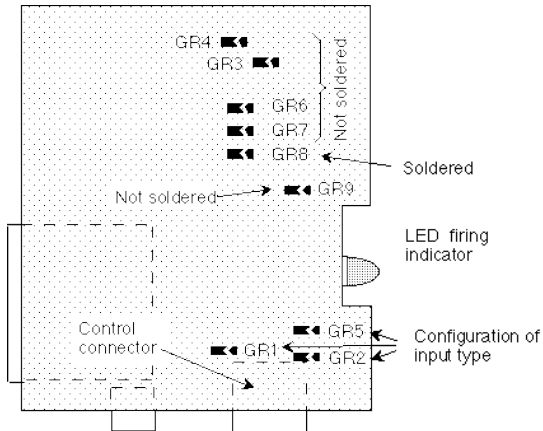

Type 2

Positioning of 'Coffee beans' on board Type 2 (solder-side view)

EUROTHERM CONTROLS LIMITED

UK SALES OFFICE

Eurotherm Controls Limited
Faraday Close, Durrington
Worthing
West Sussex BN13 3PL
TelephoneSales: (01903) 695888
695777 Technical: (01903)
695444 Service: (01903)
Fax (01903) 695666

Sales and support in over 30 countries worldwide

For countries not listed overleaf
enquiries/orders to:

Eurotherm Controls Limited
Export Dept.,
Faraday Close, Durrington, Worthing
West Sussex, BN13 3PL
Telephone (01903) 268500
Fax (01903) 265982
Telex 87114 EUROWG G

**Solid State Contactors TE10S
Power Controllers TE10A**



EUROTHERM

ADDENDUM

TE10S User Manual Part N°:
HA174780ENG, HA174782ENG,
HA174784ENG, HA175436ENG

TE10A User Manual Part N°:
HA175247ENG, HA175548ENG

**NOMINAL CURRENT UP TO 50 A
and
SHORT WAVE INFRARED APPLICATIONS**

© Copyright Eurotherm Automation S.A. 1997
All rights strictly reserved. No part of this document may be
stored in a retrieval system, or any form or by any means
without prior written permission from Eurotherm Automation
SA.

Part N°. HA175600 ENG - Issue 2.0 - 12/98

TECHNICAL SPECIFICATION

MAXIMUM CURRENT

In order to take into account supply voltage variations and heating element resistance dispersion (all types of heating elements including short wave infrared), a 0.8 safety coefficient must be used on the thyristor unit current rating to determine the maximum value of the load nominal current which the unit can safely control.

SHORT WAVE INFRARED (SWIR) APPLICATIONS

Applications using short wave infrared heaters in Single Cycle, Fast Cycle or Advanced Single Cycle are reserved to 16 A, 25 A and 40 A current rating.

With a safety coefficient of 0.8 the maximum current for SWIR which can be controlled is:

TE10 rating	SWIR maximum controlled current
16 A	13 A
25 A	20 A
40 A and 50 A	32 A

RANGE DIMENSIONS AND WEIGHT

Height 115 mm / Depth 92.5 mm

Models	Nominal current	Width (mm)	Weight (g)
TE10S/DC, TE10S/AC TE10S/PDSiO	16 A	35	350
	25 A	52.5	500
	40 A	87.5	850
	50 A	105	1100
TE10S/PLF TE10A/Burst TE10A/PA	16 A	52.5	550
	25 A	70	700
	40 A	105	900
	50 A	122.5	1200

THYRISTOR PROTECTION FUSE

TE10 rating	Fuse rating	Fuse & fuse-holder	
		Code	Dimensions(mm)
16 A			
25 A	20 A	FU1038/16A/00	81 x 17.5 x 68
40 A	32 A	FU1038/25A/00	81 x 17.5 x 68
50 A	50 A	FU1451/40A/00	95 x 26 x 86
	63 A	FU2258/50A/00	140 x 35 x 90

Attention! For SWIR applications, the high-speed fuse must not be used

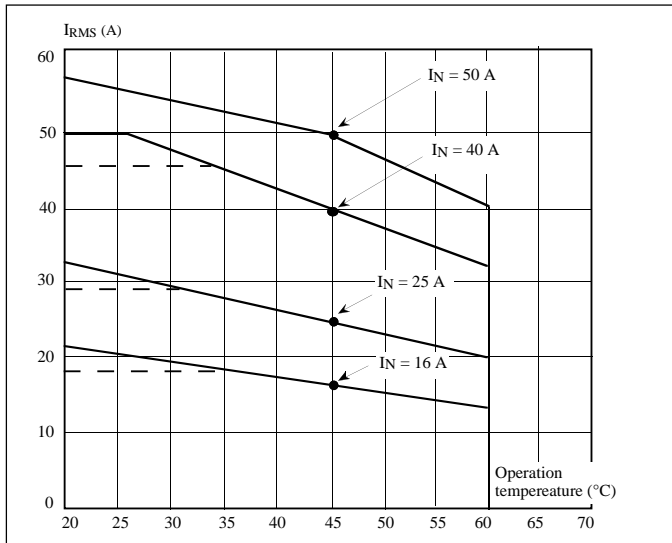

Current derating as a fonction of ambient temperature (I_N = nominal current at 45°C)

Dotted line : limit due to recommended fuse