

HANDBOOK OF OPERATIONAL AMPLIFIER APPLICATIONS

Bruce Carter and Thomas R. Brown

ABSTRACT

While in the process of reviewing Texas Instruments applications notes, including those from Burr-Brown – I uncovered a couple of treasures, this handbook on op amp applications and one on active RC networks. These old publications, from 1963 and 1966, respectively, are some of the finest works on op amp theory that I have ever seen. Nevertheless, they contain some material that is hopelessly outdated. This includes everything from the state of the art of amplifier technology, to the parts referenced in the document – even to the symbol used for the op amp itself:

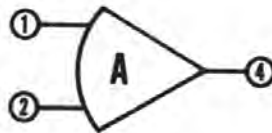

These numbers in the circles referred to pin numbers of old op amps, which were potted modules instead of integrated circuits. Many references to these numbers were made in the text, and these have been changed, of course.

In revising this document, I chose to take a minimal approach to the material out of respect for the original author, – Thomas R. Brown, leaving as much of the original material intact as possible while making the document relevant to present day designers.

There were some sections that were deleted or substantially changed:

- “Broadbanding” operational amplifier modules – replaced with discussion of uncompensated operational amplifiers.
- Open loop applications and Comparators – Applications showing an operational amplifier used open loop, as a comparator have been deleted. At the time of original publication, there were no dedicated comparator components. Good design techniques now dictate using a comparator instead of an operational amplifier. There are ways of safely using an operational amplifier as a comparator – if the output stage is designed to be used that way - as in a voltage limiting operational amplifier – or if clamping is added externally that prevents the output from saturating. These applications are shown.
- Testing Operational Amplifiers – a section that had become hopelessly outdated. Testing techniques are now tailored to the individual amplifier, to test for parameters important to its intended purpose or target end equipment.

- Some other application circuits were eliminated – if they were deemed impractical in the light of today's technology.

This handbook has also been reorganized to eliminate some redundancy, and place all application circuits in one location.

The reader is cautioned that proper decoupling techniques should be followed with operational amplifiers. Decoupling components are omitted from applications schematics in this document for clarity. Consult reference 2 for proper decoupling techniques.

I also cleaned up grammatical and spelling mistakes in the original.

--- Bruce Carter, Texas Instruments Applications

(Excerpts from) Thomas Brown's original Preface:

The purpose of this handbook is to provide a single source of information covering the proper design of circuits employing the versatile modern operational amplifier. This manual will be helpful to the experienced user of operational amplifiers, as well as the new user, in extending the range of potential applications in which these devices can be used to advantage.

It is assumed that the reader will have a basic knowledge of electronics, but no particular knowledge of operational amplifiers is needed to use this handbook. The operational amplifier is treated as a circuit component inherently subject to certain rules of operation. The design of the operational amplifiers themselves is considered only when necessary to describe their less evident properties.

Readers with a working knowledge of operational amplifiers will want to refer directly to the circuit collection. Readers whose job functions have not previously brought them in contact with operational amplifiers will want to proceed directly through the handbook until the desired degree of familiarity is obtained.

Refinements are continuously being made in the design and application of operational amplifiers, yet the basic principles of application remain the same. Please do not hesitate to contact Texas Instruments at any time with questions or comments arising from the use of this handbook. It is, after all, intended for you, the user.

--- Thomas R. Brown, Jr.

Contents

INTRODUCTION..... 7

 Computation Control Instrumentation 7

 The Feedback Technique 7

 Notation and Terminology 8

 Input Terminals 9

 Output Terminals 9

 Power Connections 10

 Summary of Notation 10

 Electrical Circuit Models 10

 Circuit Notation 11

 The Ideal Operational Amplifier 12

 Defining the Ideal Operational Amplifier 12

 A Summing Point Restraint 13

CIRCUITS AND ANALYSES USING THE IDEAL OPERATIONAL AMPLIFIER 14

 The Desirability of Feedback 14

 Two Important Feedback Circuits 15

 Voltage Follower 15

 Non-Inverting Amplifier 17

INVERTING AMPLIFIER 18

 Intuitive Analysis Techniques 19

 Current Output 20

 Reactive Elements 20

 Integrator 21

 Differentiator 21

 Voltage Adder 23

 Scaling Summer 23

 Combining Circuit Functions 24

 Differential Input Amplifier 24

 Balanced Amplifier 25

 Ideal-Real Comparison 27

CHARACTERISTICS OF PRACTICAL OPERATIONAL AMPLIFIERS 29

 Open Loop Characteristics 29

 Open Loop Operation 30

 Output Limiting 30

FREQUENCY DEPENDENT PROPERTIES 31

 Introduction 31

 Open Loop Gain and the Bode Plot 31

 Bode Plot Construction 31

 Closed Loop Gain 32

 Stability 33

 Compensation 33

 Compensation Changes 34

 Bandwidth 35

 Loop Gain 35

 The Significance of Loop Gain 36

BODE PLOTS AND BASIC PRACTICAL CIRCUITRY 37

 Voltage Follower 37

Inverter	37
X1000 Amplifier	38
Differentiator	38
INTEGRATOR	40
OTHER IMPORTANT PROPERTIES OF OPERATIONAL AMPLIFIERS.....	41
Summing Point Restraints	41
Closed Loop Impedance Levels.....	42
Output Impedance	42
Input Impedance.....	43
Differential Inputs and Common Mode Rejection.....	44
The Common Mode Voltage Limit	44
Offset.....	44
Drift 45	
Capacitive Loading	45
VOLTAGE DETECTORS AND COMPARATORS	46
Voltage Limiting Operational Amplifiers	46
THE VOLTAGE FOLLOWER	49
BUFFERS AND ISOLATION AMPLIFIERS	50
Inverting Buffer Adjustable Gain	50
Balanced Output.....	50
VOLTAGE AND CURRENT REFERENCES.....	50
Isolated Standard Cell	51
Constant Current Generator	51
Buffer Variation.....	52
Presetable Voltage Source	52
Reference Voltage Supply	52
THE NON-INVERTING AMPLIFIER	53
THE INVERTING AMPLIFIER	54
INTEGRATORS	55
PRACTICAL INTEGRATORS.....	55
Simple Integrators	56
Summing Integrator	58
Double Integrator.....	58
Differential Integrator	59
AC Integrator	59
Augmenting Integrator	59
DIFFERENTIATORS.....	61
With "Stop"	61
Low Noise	62
Augmented Differentiator.....	62
THE VOLTAGE SUMMER.....	63
SUMMING AND AVERAGING AMPLIFIERS.....	64
Adder.....	64
Scaling Adder	64
Direct Addition	65
Averager.....	65
Weighted Average	66
THE DIFFERENTIAL INPUT AMPLIFIER.....	67
Adder-Subtractor or Floating Input Combiner	68

THE DIFFERENTIAL (BALANCED) OUTPUT AMPLIFIER.....	69
DC AMPLIFIERS	70
Simple Inverting sign changing amplifier.....	70
Chopper Stabilized	70
Simple Gain Control.....	70
Linear Gain Control	71
Simple Non-Inverting	71
Power Booster.....	71
Differential Output.....	73
Gain Control	73
Inverting Gain Control.....	73
DIFFERENTIAL AMPLIFIERS	74
Subtractor.....	74
Difference Amplifier	74
Common Mode Rejection	75
Differential Input-Output.....	75
AC AMPLIFIERS	76
DC Amplifiers with Blocking Capacitors	76
Simple Amplifier	76
Single Supply	76
Non-Inverting.....	77
Double Rolloff.....	77
AC Preamplifier	78
CURRENT OUTPUT DEVICES.....	79
Feedback Loop.....	79
Simple Meter Amplifier.....	79
Meter Amplifier	80
Current Injector.....	80
Linear Current Source	81
Deflection Coil Driver	82
OSCILLATORS AND MULTI VIBRATORS	83
Simple Oscillator.....	83
Wien Bridge Oscillator	83
PHASE LEAD AND LAG NETWORKS	84
Lag Element	84
Adjustable Lag.....	84
Lag value linear with R setting	85
Adjustable Lead.....	85
Lead-Lag	86
Time Delay	86
ADDITIONAL CIRCUITS	87
Absolute Value	87
Peak Follower.....	87
Precision Rectifier.....	88
AC to DC Converter.....	88
Full Wave Rectifier	89
Rate Limiter	89
Time Delay	90
Selective Amplifier	91
SECTION III: SELECTING THE PROPER OPERATIONAL AMPLIFIER	92

Focus on Limiting Specifications..... 92
 Avoid Closed Loop vs. Open Loop Confusion..... 92
 Selection Check List..... 92
 Assistance Available from Texas Instruments..... 93
References..... 93

Figures

Figure 1. Operational Amplifier with Feedback 8
Figure 2. Texas Instruments Standard Symbols 8
Figure 3. Op Amp Package Options 9
Figure 4. Power Supply Connections..... 10
Figure 5. Summary of Notation Introduced..... 10
Figure 6. Circuit Model of the Single Ended Operational Amplifier 10
Figure 7. Circuit Model of the Differential Output Operational Amplifier..... 11
Figure 8. Notation and Terms Used in Closed Loop Circuits 11
Figure 9. Equivalent Circuit of the Ideal Operational Amplifier 12
Figure 10. Open Loop Operation 14
Figure 11. Basic Amplifier Circuits..... 15
Figure 12. Voltage Follower 15
Figure 13. Feedback Resistor Added to the Voltage Follower 16
Figure 14. Non-Inverting Amplifier 17
Figure 15. Non-Inverting Amplifier Re-Drawn to Show Similarity to the Voltage Follower..... 17
Figure 16. Non-Inverting Amplifier Analyzed as a Voltage Divider 17
Figure 17. Inverting Amplifier 18
Figure 18. Intuitive Devices for Analysis of Circuits Based on the Inverting Amplifier..... 19
Figure 19. Inverting Amplifier as a Linear Current Output Device 20
Figure 20. General Form of the Inverting Amplifier..... 20
Figure 21. Integrator Circuit..... 21
Figure 22. Differentiator Circuit 21
Figure 23. An Intuitive Picture of the Differentiator..... 22
Figure 24. Voltage Adding Circuit 23
Figure 25. Scaling Summer Circuit..... 24
Figure 26. Differential Input Amplifier Circuit 24
Figure 27. Analyzing the Differential Input Amplifier Circuit as Non-Inverting Amplifier 25
Figure 28. The Differential Output Operational Amplifier 26
Figure 29. Equivalent Circuit of a Real Operational Amplifier 27
Figure 30. Amplifier Circuit Using a Real Operational Amplifier 27
Figure 31. Input-Output Transfer Relation for the Open Loop Operational Amplifier..... 29
Figure 32. Bode Plot of an Operational Amplifier and its Linear Approximation 31
Figure 33. Sketching the Bode Plot Approximation for Figure 32..... 32
Figure 34. Closed Loop Gain of a X100 (40 dB) Inverting Amplifier..... 32
Figure 35. The Effect of Internal Phase Compensation..... 33
Figure 36. Composite Bode Plots Showing Stability Provided by Proper Phase Compensation..... 34
Figure 37. The Effect of Internal Compensation for Gains Greater Than 1..... 34
Figure 38. Instability when an Uncompensated Amplifier is Used at Gains Lower Than the Designated Level..... 35
Figure 39. Loss of High Frequency Response When Heavy Feedback is Used..... 36
Figure 40. Voltage Follower Circuit 37
Figure 41. Voltage Inverter Circuit..... 37

Figure 42.	60 dB Amplifier Circuits.....	38
Figure 43.	Differentiator Circuit	38
Figure 44.	Differentiator With “Stop”	39
Figure 45.	Differentiator With “Double Stop”.....	39
Figure 46.	Integrator Circuit.....	40
Figure 47.	DC Summing Point Conditions	41
Figure 48.	Voltage Follower	42
Figure 49.	Voltage Follower	43
Figure 50.	Inverting Amplifier with Current Offset Control	44
Figure 51.	Drift Stabilizing the Inverting Amplifier	45
Figure 52.	Gain Peaking Caused by Capacitive Loading.....	45
Figure 53.	Voltage Limiting Operational Amplifiers	46
Figure 54.	Fully Clamped Voltage Comparator.....	47

Tables

Table 1.	Compound Amplifier, Resulting Performance	72
Table 2.	Current Source Scaling Resistors	81

INTRODUCTION

The operational amplifier is an extremely efficient and versatile device. Its applications span the broad electronic industry filling requirements for signal conditioning, special transfer functions, analog instrumentation, analog computation, and special systems design. The analog assets of simplicity and precision characterize circuits utilizing operational amplifiers.

Computation Control Instrumentation

Originally, the term, “Operational Amplifier,” was used in the computing field to describe amplifiers that performed various mathematical operations. It was found that the application of negative feedback around a high gain DC amplifier would produce a circuit with a precise gain characteristic that depended only on the feedback used. By the proper selection of feedback components, operational amplifier circuits could be used to add, subtract, average, integrate, and differentiate.

As practical operational amplifier techniques became more widely known, it was apparent that these feedback techniques could be useful in many control and instrumentation applications. Today, the general use of operational amplifiers has been extended to include such applications as DC Amplifiers, AC Amplifiers, Comparators, Servo Valve Drivers, Deflection Yoke Drivers, Low Distortion Oscillators, AC to DC Converters, Multivibrators, and a host of others.

What the operational amplifier can do is limited only by the imagination and ingenuity of the user. With a good working knowledge of their characteristics, the user will be able to exploit more fully the useful properties of operational amplifiers.

The Feedback Technique

The precision and flexibility of the operational amplifier is a direct result of the use of negative feedback. Generally speaking, amplifiers employing feedback will have superior operating characteristics at a sacrifice of gain.

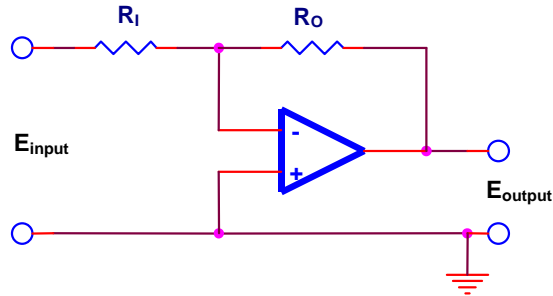

$$\frac{E_{\text{output}}}{E_{\text{input}}} = -\frac{R_O}{R_I}$$

Figure 1. Operational Amplifier with Feedback

With enough feedback, the closed loop amplifier characteristics become a function of the feedback elements. In the typical feedback circuit, figure 1, the feedback elements are two resistors. The precision of the “closed loop” gain is set by the ratio of the two resistors and is practically independent of the “open loop” amplifier. Thus, amplification to almost any degree of precision can be achieved with ease.

Notation and Terminology

Texas Instruments employs the industry standard operational amplifier symbols shown in figure 2. Power pins are often omitted from the schematic symbol when the power supply voltages are explicit elsewhere in the schematic. Some op amp symbols also include offset nulling pins, enable / disable pins, output voltage threshold inputs, and other specialized functions.

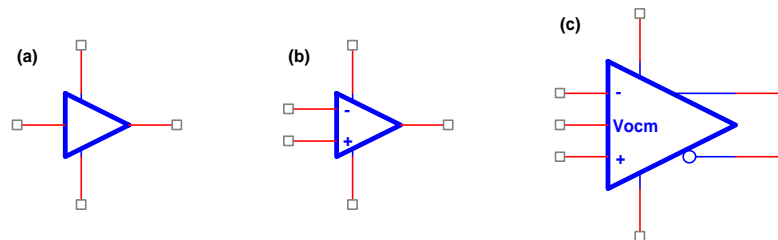

Figure 2. Texas Instruments Standard Symbols

- Symbol (a) is a buffer op amp
- Symbol (b) is a differential input, single ended output op amp. This symbol represents the most common types of op amps, including voltage feedback, and current feedback. It is often times pictured with the non-inverting input at the top and the inverting input at the bottom.
- Symbol (c) is a differential input, differential output op amp. The outputs can be thought of as “inverting” and “non-inverting”, and are shown across from the opposite polarity input for easy completion of feedback loops on schematics.

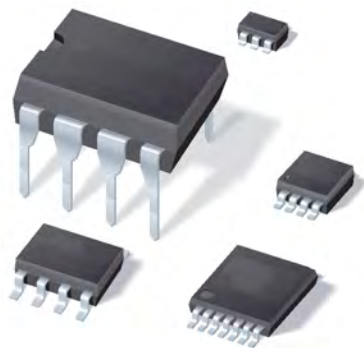

Figure 3. Op Amp Package Options

Figure 3 represents a small number of the many op amp package options offered by Texas Instruments.

Input Terminals

In figures 2b and 2c, the “-“ pin is the “inverting input” or “summing point,” meaning a positive voltage produces a negative voltage at the output on symbol (b), and the top (non-inverting) output on symbol (c). When only one input or output terminal exists, its voltage is measured with respect to ground. This is indicated by the term, “single ended.” It is a popular ambiguity not to explain if a circuit, earth, or chassis ground is meant by this, so the use of a common line is preferred with the ground symbol used to indicate which line is the common.

When there is an inverting input, such as in figures 2b and 2c, the voltage at the inverting input may be measured with respect to the non-inverting input. In use, such an amplifier responds to the difference between the voltages at the inverting and non-inverting inputs, i.e., a “differential input.”

In many circuits, the non-inverting input is connected to ground. Due to the high gain of operational amplifiers, only a very small input voltage then appears at the output and the output is virtually at ground potential. For purposes of circuit analysis, it can be assumed to be ground - a “virtual ground.”

Output Terminals

The relation between the inverting and non-inverting inputs and the output was stated above. For the symbol of (c) the second output voltage is approximately equal and opposite in polarity to the other output voltage, each measured with respect to ground. When the two outputs are used as the output terminals without ground reference, they are known as “differential outputs”.

Power Connections

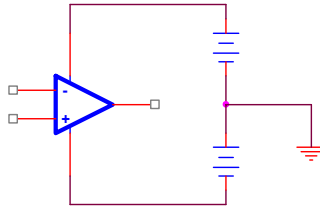

Figure 4. Power Supply Connections

Power is supplied to each of these units at connections as shown in figure 4. Such a connection is implied in all operational amplifier circuits. The dual supply presents the same absolute value of voltage to ground from either side, while the center connection ultimately defines the common line and ground potential. The exceptions to this are AC amplifier circuits that may use a single power supply. This is accomplished by creating a floating AC ground with DC blocking capacitors. In such circuits, a source of “half-supply” creates a “virtual ground” exactly half way between the positive supply and ground potentials.

Summary of Notation

If it is understood that there may not be two inputs or two outputs, figure 5 is a concise summary of the notation introduced. The arrows denote the “direction” of the polarity at each pin.

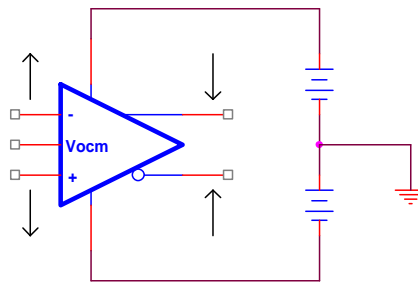

Figure 5. Summary of Notation Introduced

Electrical Circuit Models

The simplified models of the differential input operational amplifiers are shown in figures 6 and 7.

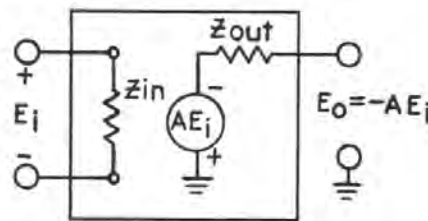

Figure 6. Circuit Model of the Single Ended Operational Amplifier

As indicated in figure 6, the operational amplifier can be represented by an ideal voltage source whose value depends on the input voltage appearing across the inverting and non-inverting inputs plus the effects of finite input and output impedances. The value, A , is known as the open loop (without feedback) gain of the operational amplifier.

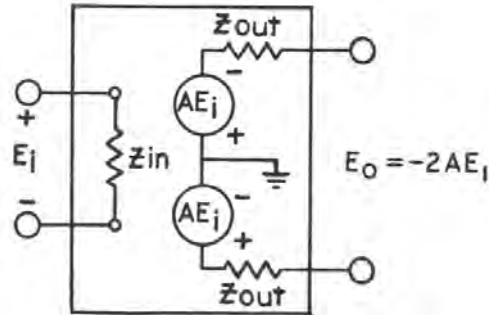

Figure 7. Circuit Model of the Differential Output Operational Amplifier

The simplified model of the differential output operational amplifier (figure 7) is an accurate approximation only under special conditions of feedback (see “Balanced Amplifier” later in this handbook). Figure 6 represents the model of the differential output type when it is used as a single ended output device; the inverting output simply being ignored.

Circuit Notation

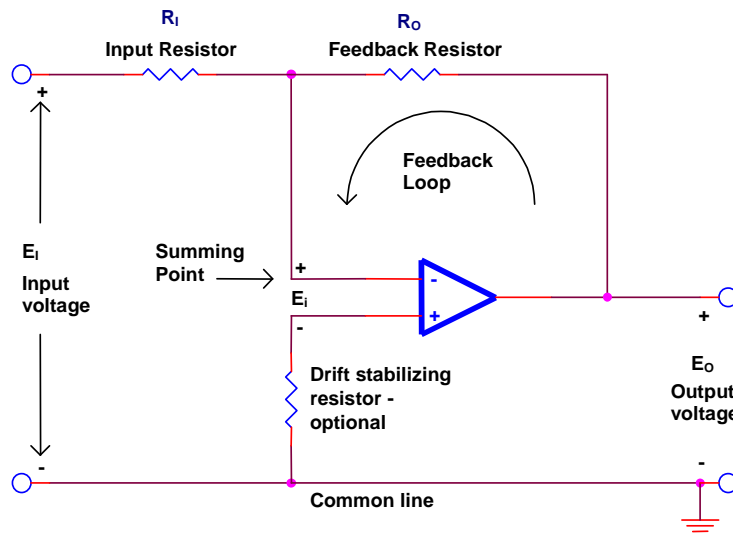

Figure 8. Notation and Terms Used in Closed Loop Circuits

A circuit that will become very familiar as we progress into practical amplifier circuits and the notation we will use are shown in figure 8. Resistors R_i and R_o are replaced by complex impedances Z_i and Z_o in some applications of this circuit.

The Ideal Operational Amplifier

In order to introduce operational amplifier circuitry, we will use an ideal model of the operational amplifier to simplify the mathematics involved in deriving gain expressions, etc., for the circuits presented. With this understanding as a basis, it will be convenient to describe the properties of the real devices themselves in later sections, and finally to investigate circuits utilizing practical operational amplifiers.

To begin the presentation of operational amplifier circuitry, then, it is necessary first of all to define the properties of a mythical “perfect” operational amplifier. The model of an ideal operational amplifier is shown in figure 9.

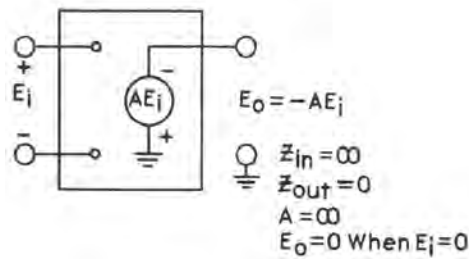

Figure 9. Equivalent Circuit of the Ideal Operational Amplifier

Defining the Ideal Operational Amplifier

- **Gain:** The primary function of an amplifier is to amplify, so the more gain the better. It can always be reduced with external circuitry, so we assume gain to be infinite.
- **Input Impedance:** Input impedance is assumed to be infinite. This is so the driving source won't be affected by power being drawn by the ideal operational amplifier.
- **Output Impedance:** The output impedance of the ideal operational amplifier is assumed to be zero. It then can supply as much current as necessary to the load being driven.
- **Response Time:** The output must occur at the same time as the inverting input so the response time is assumed to be zero. Phase shift will be 180° . Frequency response will be flat and bandwidth infinite because AC will be simply a rapidly varying DC level to the ideal amplifier.
- **Offset:** The amplifier output will be zero when a zero signal appears between the inverting and non-inverting inputs.

A Summing Point Restraint

An important by-product of these properties of the ideal operational amplifier is that the summing point, the inverting input, will conduct no current to the amplifier. This property is to become an important tool for circuit analysis and design, for it gives us an inherent restraint on our circuit - a place to begin analysis. Later on, it will also be shown that both the inverting and non-inverting inputs must remain at the same voltage, giving us a second powerful tool for analysis as we progress into the circuits of the next section.

CIRCUITS AND ANALYSES USING THE IDEAL OPERATIONAL AMPLIFIER

A description of the ideal operational amplifier model was presented in the last section, and the introduction of complete circuits may now begin. Though the ideal model may seem a bit remote from reality - with infinite gain, bandwidth, etc., it should be realized that the closed loop gain relations which will be derived in this section are directly applicable to real circuits - to within a few tenths of a percent in most cases. We will show this later with a convincing example.

The Desirability of Feedback

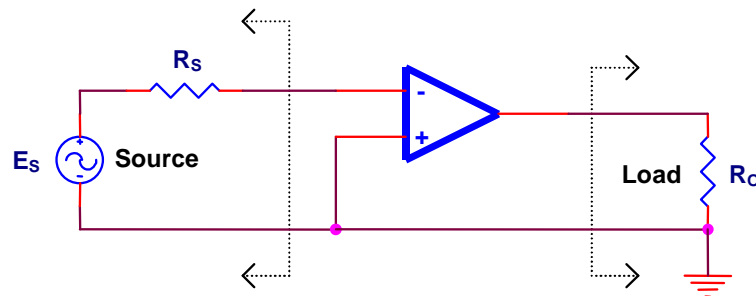

Figure 10. Open Loop Operation

Consider the open loop amplifier used in the circuit of figure 10. Note that no current flows from the source into the inverting input - the summing point restraint derived in the previous section - hence, there is no voltage drop across R_S and E_S appears across the amplifier input. When E_S is zero, the output is zero. If E_S takes on any non-zero value, the output voltage increases to saturation, and the amplifier acts as a switch.

The open loop amplifier is not practical - once an op amp is pushed to saturation, its behavior is unpredictable. Recovery time from saturation is not specified for op amps (except voltage limiting types). It may not recover at all; the output may latch up. The output structure of some op amps, particularly rail-to-rail models, may draw a lot of current as the output stage attempts to drive to one or the other rail. For more details on op amps in open loop operation, consult reference 1.

Two Important Feedback Circuits

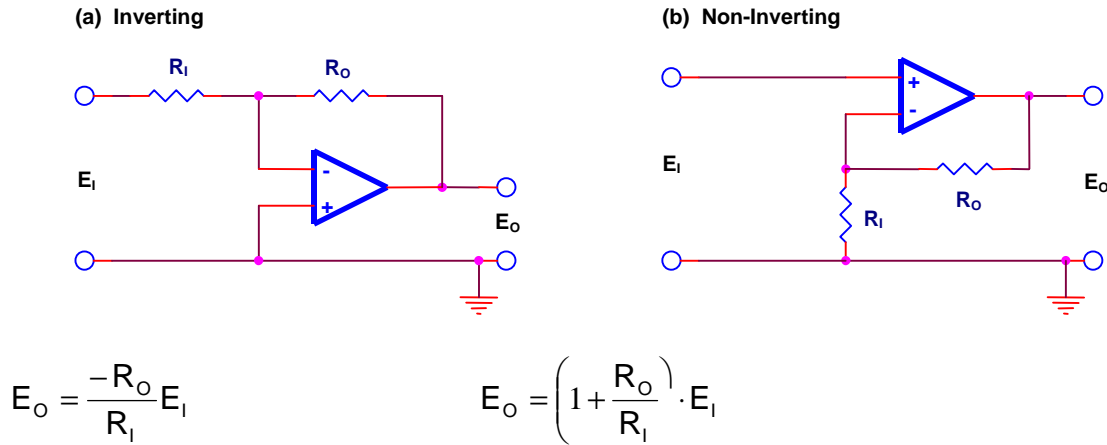

Figure 11. Basic Amplifier Circuits

Figure 11 shows the connections and the gain equations for two basic feedback circuits. The application of negative feedback around the ideal operational amplifier results in another important summing point restraint: The voltage appearing between the inverting and non-inverting inputs approaches zero when the feedback loop is closed.

Consider either of the two circuits shown in figure 11. If a small voltage, measured at the inverting input with respect to the non-inverting input, is assumed to exist, the amplifier output voltage will be of opposite polarity and can always increase in value (with infinite output available) until the voltage between the inputs becomes infinitesimally small. When the amplifier output is fed back to the inverting input, the output voltage will always take on the value required to drive the signal between the inputs toward zero.

The two summing point restraints are so important that they are repeated:

1. No current flows into either input terminal of the ideal operational amplifier.
2. When negative feedback is applied around the ideal operational amplifier, the differential input voltage approaches zero.

These two statements will be used repeatedly in the analysis of the feedback circuits to be presented in the rest of this section.

Voltage Follower

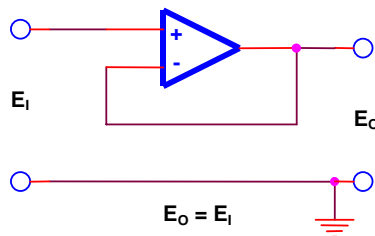

Figure 12. Voltage Follower

The circuit in figure 12 demonstrates how the addition of a simple feedback loop to the open loop amplifier converts it from a device of no usefulness to one with many practical applications.

Analyzing this circuit, we see that the voltage at the non-inverting input is E_i , the voltage at the inverting input approaches the voltage at the non-inverting input, and the output is at the same voltage as the inverting input. Hence, $E_o = E_i$, and our analysis is complete. The simplicity of our analysis is evidence of the power and utility of the summing point restraints we derived and have at our disposal.

Our result also may be verified by mathematical analysis very simply. Since no current flows at the non-inverting input, the input impedance of the voltage follower is infinite. The output impedance is just that of the ideal operational amplifier itself, i.e. zero. Note also that no current flows through the feedback loop, so any arbitrary (but finite) resistance may be placed in the feedback loop without changing the properties of the ideal circuit, shown in figure 13. No voltage would appear across the feedback element and the same mathematical analysis would hold.

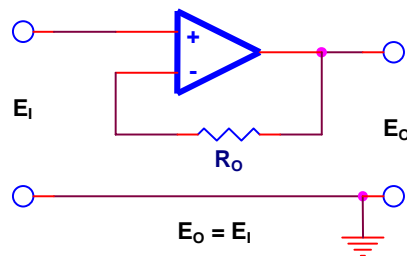

Figure 13. Feedback Resistor Added to the Voltage Follower

The feedback resistor is of particular importance if the op amp selected is a current-feedback type. The stability of current-feedback op amps is dependent entirely on the value of feedback resistor selected, and the designer should use the value recommended on the data sheet for the device.

Unity gain circuits are used as electrical buffers to isolate circuits or devices from one another and prevent undesired interaction. As a voltage following power amplifier, this circuit will allow a source with low current capabilities to drive a heavy load.

The gain of the voltage follower with the feedback loop closed (closed loop gain) is unity. The gain of the ideal operational amplifier without a feedback loop (open loop gain) is infinity. Thus, we have traded gain for control by adding feedback. Such a severe sacrifice of gain - from infinity to unity - is not necessary in most circuits. The rest of the ideal circuits to be studied will give any (finite) closed loop gain desired while maintaining control through feedback.

Non-Inverting Amplifier

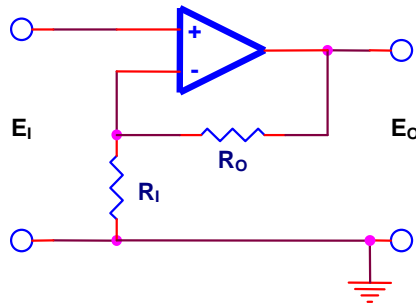

$$E_o = \left(1 + \frac{R_o}{R_i}\right) \cdot E_i$$

Figure 14. Non-Inverting Amplifier

The circuit in figure 14 was chosen for analysis next because of its relation to the voltage follower. It is re-drawn as in figure 15, which makes it evident that the voltage follower is simply a special case of the non-inverting amplifier.

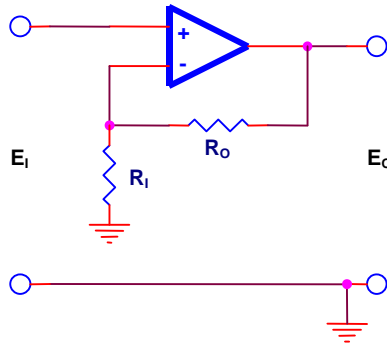

Figure 15. Non-Inverting Amplifier Re-Drawn to Show Similarity to the Voltage Follower

Since no current flows into the inverting input, R_o and R_i form a simple voltage divider (figure 16).

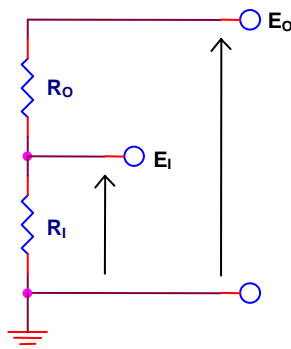

Figure 16. Non-Inverting Amplifier Analyzed as a Voltage Divider

The same voltage must appear at the inverting and non-inverting inputs, so that:

$$(E -) = (E +) = E_1$$

From the voltage division formula:

$$E_1 = \frac{R_i}{R_i + R_o} \cdot E_o$$

$$\frac{E_o}{E_1} = \frac{R_i + R_o}{R_i} = 1 + \frac{R_o}{R_i}$$

The input impedance of the non-inverting amplifier circuit is infinite since no current flows into the inverting input. Output impedance is zero since output voltage is ideally independent of output current. Closed loop gain is $1 + \frac{R_o}{R_i}$ hence can be any desired value above unity.

Such circuits are widely used in control and instrumentation where non-inverting gain is required.

INVERTING AMPLIFIER

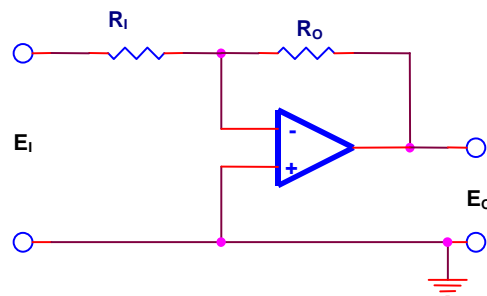

$$\frac{E_o}{E_i} = -\frac{R_o}{R_i}$$

Figure 17. Inverting Amplifier

The inverting amplifier appears in figure 17. This circuit and its many variations form the bulk of commonly used operational amplifier circuitry. Single ended input and output versions were first used, and they became the basis of analog computation. Today's modern differential input amplifier is used as an inverting amplifier by grounding the non-inverting input and applying the input signal to the inverting input terminal.

Since the amplifier draws no input current and the input voltage approaches zero when the feedback loop is closed (the two summing point restraints), we may write:

$$\frac{E_i}{R_i} = \frac{E_o}{R_o} = 0$$

Hence:

$$\frac{E_o}{E_i} = -\frac{R_o}{R_i}$$

Input impedance to this circuit is not infinite as in the two previous circuits, the inverting input is at ground potential so the driving source effectively “sees” R_i as the input impedance. Output impedance is zero as in the two previous circuits. Closed loop gain of this circuit is $-\frac{R_o}{R_i}$.

Intuitive Analysis Techniques

The popularity of the inverting amplifier has been mentioned already. In control and instrumentation applications, its practical value lies in the ease with which desired input impedance and gain values can be tailored to fit the requirements of the associated circuitry. Its utility is reflected in the variety of intuitive devices that are commonly used to simplify its analysis.

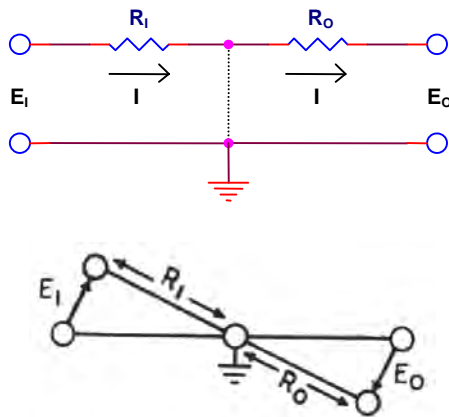
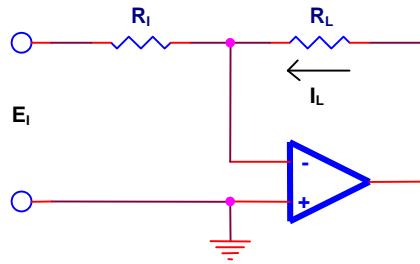

Figure 18. Intuitive Devices for Analysis of Circuits Based on the Inverting Amplifier

If we draw the summing point, the inverting input and output of the inverting amplifier as in figure 18, the dotted line serves as a reminder that the inverting input is at ground potential but conducts no current to ground. The output can supply any needed current, and analysis quickly becomes rote. Another such device uses the action of a lever to show as vectors the voltage relations that exist using the inverting input as the fulcrum.

Current Output



$$I_L = -\frac{E_i}{R_i}$$

Figure 19. Inverting Amplifier as a Linear Current Output Device

So far, we have considered voltage as the output of the inverting amplifier, but it also finds wide application as a current supplying device. This is accomplished by placing the load in the feedback loop as in figure 19. Since the inverting input is ground potential, the current through

R_i is $\frac{E_i}{R_i}$. No current flows into the inverting input, so $I_L = -\frac{E_i}{R_i}$, which is independent of R_L . In

similar configurations, the inverting amplifier can serve as a linear meter amplifier or deflection coil driver. Input impedance is R_i as before.

Reactive Elements

Though only resistances have been used in the input and feedback loop of the amplifiers presented so far, the general form of the inverting amplifier is shown in figure 20, where Z_o and Z_i are complex impedances in general.

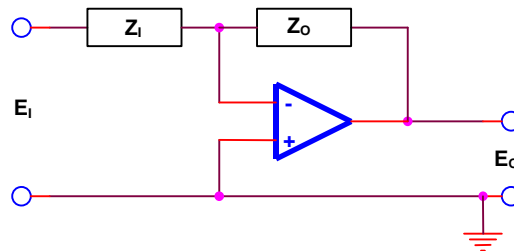

$$\frac{E_o}{E_i} = -\frac{Z_o}{Z_i}$$

Figure 20. General Form of the Inverting Amplifier

The gain relation may be verified in the same manner as for the resistive case by summing currents using complex notation. There is an area of control application utilizing this general form of the inverting amplifier. Many times it is necessary to construct a network with some specifically designated transfer function.

By reducing this transfer function to the ratio of two polynomials, a table may be consulted for suitable passive networks to be used in the inverting amplifier.

Other uses of reactive elements are found in the integrator and differentiator circuits that follow.

Integrator

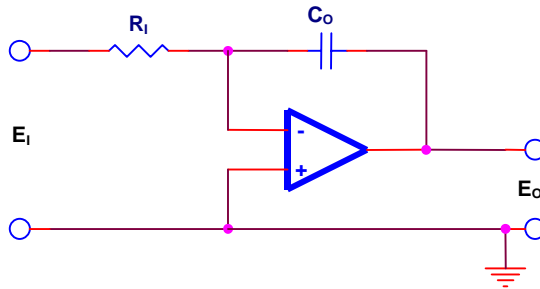

$$E_o = \frac{-1}{R_i C_o} \int E_i dt$$

Figure 21. Integrator Circuit

If a capacitor is used as the feedback element in the inverting amplifier, shown in figure 21, the result is an integrator. An intuitive grasp of the integrator action may be obtained from the statement under the section, "Current Output," that current through the feedback loop charges the capacitor and is stored there as a voltage from the output to ground. This is a voltage input current integrator.

Differentiator

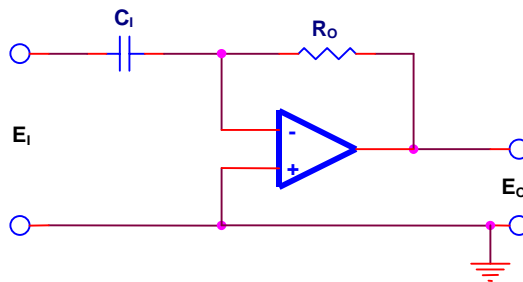

$$E_o = -R_o C_i \frac{dE_i}{dt}$$

Figure 22. Differentiator Circuit

Using a capacitor as the input element to the inverting amplifier, figure 22, yields a differentiator circuit. Consideration of the device in figure 23 will give a feeling for the differentiator circuit.

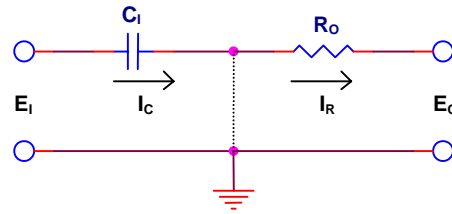

Figure 23. An Intuitive Picture of the Differentiator

Since the inverting input is at ground potential:

$$I_C = C_1 \frac{dE_I}{dt}, \text{ and } I_C - I_R = 0$$

so that:

$$C_1 \frac{dE_I}{dt} + \frac{E_O}{R_O} = 0$$

$$E_O = -R_O C_1 \frac{dE_I}{dt}$$

It should be mentioned that of all the circuits presented in this section, the differentiator is the one that will operate least successfully with real components. The capacitive input makes it particularly susceptible to random noise and special techniques will be discussed later for remedying this effect.

Voltage Adder

In a great many practical applications the input to the inverting amplifier is more than one voltage. The simplest form of multiple inputs is shown in figure 24.

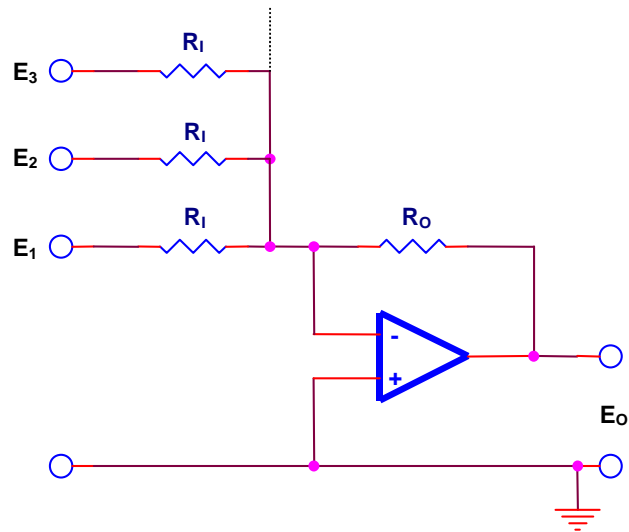

$$E_o = -\frac{R_o}{R_1}(E_1 + E_2 + E_3 + \dots)$$

Figure 24. Voltage Adding Circuit

Current in the feedback loop is the algebraic sum of the current due to each input. Each source, E_1 , E_2 , etc., contributes to the total current, and no interaction occurs between them. All inputs “see” R_1 as the input impedance, while gain is $-\frac{R_o}{R_1}$. Direct voltage addition may be obtained with $R_o = R_1$.

Scaling Summer

A more general form of adder allows scaling of each input before addition (figure 25).

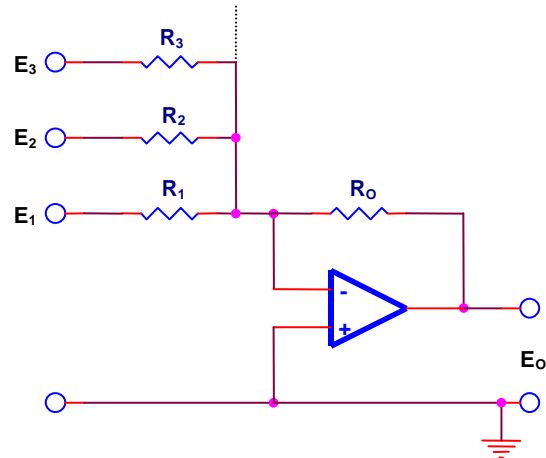

$$E_o = -R_o \left(\frac{E_1}{R_1} + \frac{E_2}{R_2} + \frac{E_3}{R_3} + \dots \right)$$

Figure 25. Scaling Summer Circuit

The adder above is obviously a special case of this circuit. Each input “sees” its respective input resistor as the input resistance.

Combining Circuit Functions

The basic inverting amplifier configuration is very flexible - so flexible, in fact, that it would be difficult to overestimate its usefulness. Additional applications that already may have occurred to the reader include: a variable gain amplifier using a potentiometer for R_1 or R_o or both; a summing integrator by using a feedback capacitor in the summing amplifier; and many others.

Differential Input Amplifier

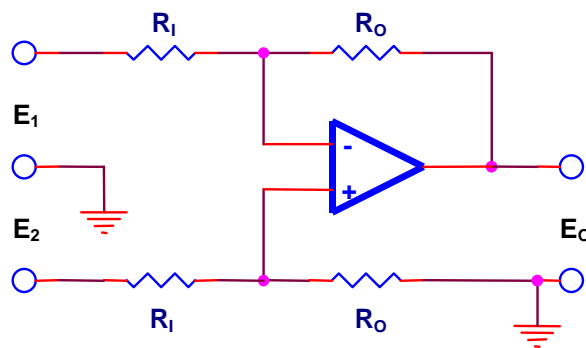

$$E_o = \frac{R_o}{R_1} (E_2 - E_1)$$

Figure 26. Differential Input Amplifier Circuit

Figure 26 shows a circuit utilizing both inputs to the differential operational amplifier. Its operation can be appreciated best by considering it a combination of the inverting and non-inverting amplifier, where the input voltage is tapped from the divider formed by the lower R_O and R_I (figure 27).

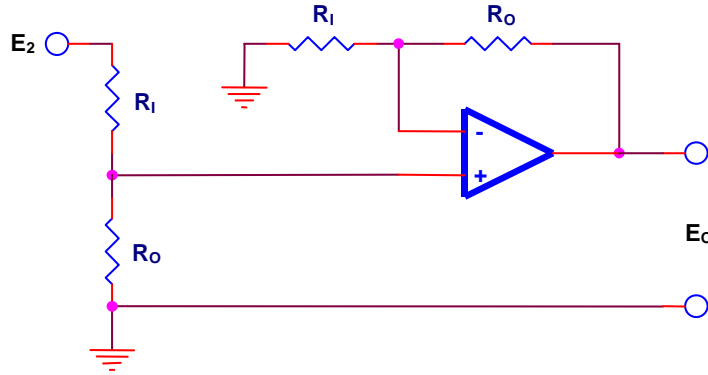

Figure 27. Analyzing the Differential Input Amplifier Circuit as Non-Inverting Amplifier

Hence, the output due to E_2 is:

$$E_o = \frac{R_o + R_i}{R_i} \left(\frac{E_2 R_o}{R_i + R_o} \right) = \frac{R_o}{R_i} E_2$$

With E_2 grounded, the circuit is simply an inverting amplifier with the non-inverting input grounded through a resistance (which conducts no current). Hence, the output due to E_1 is

$$E_o = \frac{-R_o}{R_i} E_1$$

so the total output is:

$$E_o = \frac{R_o}{R_i} (E_2 - E_1)$$

The input pins reside at the voltage level $\frac{E_2 R_o}{R_i + R_o}$, however, which may have a detrimental effect on a real operational amplifier. (See the section on common mode voltage limit.)

Since the action of the voltage divider formed by the bottom R_O and R_I is independent of the remainder of the circuit, the voltage common to the input pins is independent of E_1 . The source of E_2 "sees" $R_O + R_I$, the voltage divider itself. Output impedance is zero, as before.

Balanced Amplifier

The differential output type of operational amplifier is redrawn with its ideal equivalent in figure 28.

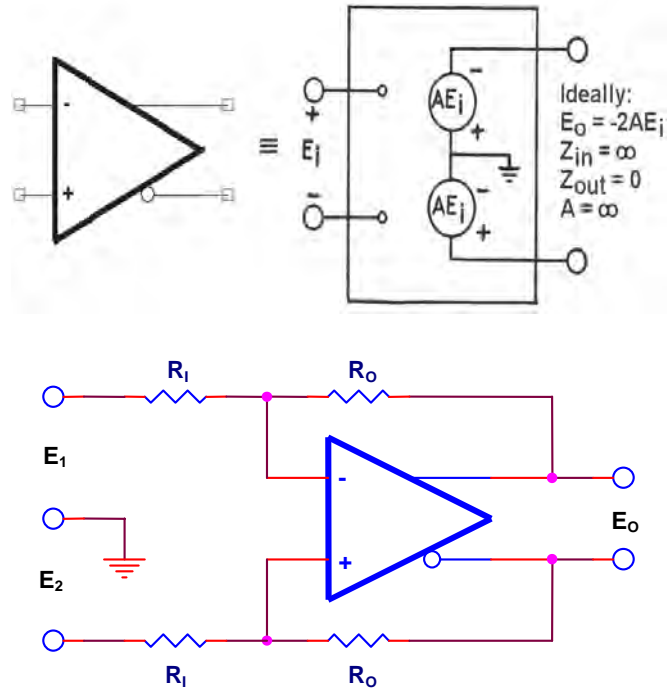

$$E_o = \frac{R_o}{R_i} (E_2 - E_1)$$

Figure 28. The Differential Output Operational Amplifier

Any of the previous single ended output circuits may use the differential output type since the relation between the inputs and non-inverting output is fixed. The roles of the input terminals may even be reversed by applying feedback across the bottom feedback pathway (inverting output to non-inverting input) instead of the non-inverting output to the inverting input. In either case, the unused output terminal may be ignored. A single feedback path only determines the voltage of the output terminal from which the feedback is taken.

To form a differential or balanced output amplifier, then, it is necessary to take feedback from both output terminals as in figure 28. This circuit is a differential form of the inverting amplifier since neither output terminal is grounded. Z_{OUT} is ideally zero, and closed loop (differential) gain is $\frac{-R_o}{R_i}$.

A differential output amplifier may be used to convert a single-ended voltage into a pair of balanced voltages by grounding either signal input. Such devices as servo motors, push-pull amplifier stages, and symmetrical transmission lines may be driven by the differential output amplifier.

Texas Instruments fully differential operational amplifiers include an additional pin - V_{OCM} . When used as an output, this pin represents the common mode voltage about which the two outputs operate. It can also be used as an input, to allow the user to set the common mode operational point from an external source, such as the reference output of a differential input analog to digital converter. The designer is cautioned not to rely on this input exclusively to set the correct DC operating point of the circuit. Voltage divider effects of input and feedback resistors can easily violate the input common mode range of the operational amplifier, and the low values of resistors used in modern fully differential circuits can cause unexpected power dissipation levels in the resistors. For more information on the correct use of the V_{OCM} pin, and setting the correct DC operating level of a fully differential operational amplifier circuit, consult reference 3.

Ideal-Real Comparison

The idealized operational amplifier has been used as a model throughout this section. Before progressing into the next section concerning real operational amplifier characteristics, it will be demonstrated by example that the gain expressions that have been derived are indeed valid in the real case.

The equivalent circuit of a real operational amplifier might appear as in figure 29.

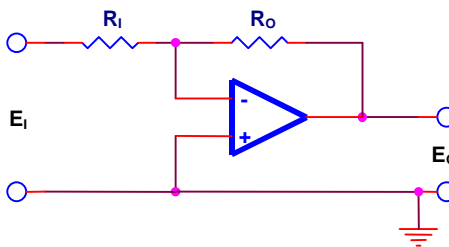

Figure 29. Equivalent Circuit of a Real Operational Amplifier

Connecting it as in figure 30 gives a X10 amplifier circuit.

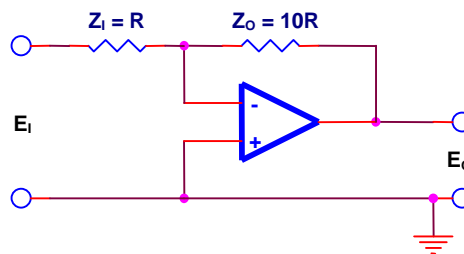

Figure 30. Amplifier Circuit Using a Real Operational Amplifier

When the effect of finite gain, input impedance, and output impedance are taken into account, the gain characteristics are given by:

$$\frac{E_o}{E_i} = -\frac{Z_o}{Z_i} \left(\frac{1}{1 + \mu} \right)$$

where:

$$\mu = \frac{\left(1 + \frac{Z_{out}}{Z_O} + \frac{Z_{out}}{Z_{load}}\right) \left(1 + \frac{Z_O}{Z_i} + \frac{Z_O}{Z_{in}}\right)}{\left(A - \frac{Z_{out}}{Z_O}\right)}$$

This may be expanded as:

$$\frac{E_o}{E_i} = \frac{-Z_O}{Z_i} (1 - \mu + \mu^2 - \mu^3 + \dots)$$

and, where $\mu \ll 1$, as is usually the case, simplifies to:

$$\frac{E_o}{E_i} = \frac{-Z_O}{Z_i} (1 - \mu)$$

Now, letting the open loop parameters take on the following values which are typical, though conservatively estimated:

$$\begin{array}{ll} A = 10,000 & Z_i = 10 \text{ k}\Omega \\ Z_{in} = 50 \text{ k}\Omega & Z_O = 100 \text{ k}\Omega \\ Z_{out} = 100 & Z_{load} = 10 \text{ k}\Omega \end{array}$$

Solving, we get $\mu = 0.0013$ (which justifies our assumption above) and the real closed loop gain is:

$$\frac{E_o}{E_i} = -10.000 + 0.013 = -9.987$$

instead of -10 which would be ideally expected.

The gain of this circuit is accurate to within 0.13% of the idealized value.

This entire error may be considered as a 'calibration' error and completely cancelled by a slight adjustment of the feedback resistor. Once such an adjustment is made, the gain accuracy of the circuit would be affected less than 0.02% should the gain of the amplifier change by 10%.

CHARACTERISTICS OF PRACTICAL OPERATIONAL AMPLIFIERS

The modern operational amplifier is a solid state, high gain, DC voltage amplifier. Practical feedback circuits employing it are based on the circuits that were derived in the preceding section using the ideal operational amplifier model. Substituting a real for an ideal operational amplifier will result in some predictable variation from ideal operation that is negligibly small in many applications. This section is intended to acquaint the reader with the characteristics of the real devices so that they may be utilized to the fullest possible extent in practical circuits.

Open Loop Characteristics

In the case of the ideal operational amplifier, circuit operation was seen to be dependent entirely on the feedback used. It is possible to use the real operational amplifier open loop, but control and stability problems are encountered due to the high open loop gain (X100000 typically at DC). Random noise from the input circuit and noise generated within the operational amplifier itself plus any variations in amplifier characteristics due to temperature change or aging components are all multiplied by open loop gain. Slight variations in the manufactured unit become noticeable due to this effect; hence open loop specifications are sometimes given conservative "typical" values.

Open loop operational amplifier specifications have a relatively remote connection to closed loop operation of a circuit since they do not as much define circuit operation as they do limit it. The sheer numbers of useful operational amplifier circuits make it impossible for a manufacturer to completely specify closed loop operation. Since each closed loop circuit is, in essence, a special case, it is necessary to understand both open and closed loop characteristics before the intelligent design of circuitry using operational amplifier can begin. Any statements that are to be made about operational amplifier circuits must be qualified by the information "open loop" or "closed loop," and the character of the feedback should be specified for "closed loop" information.

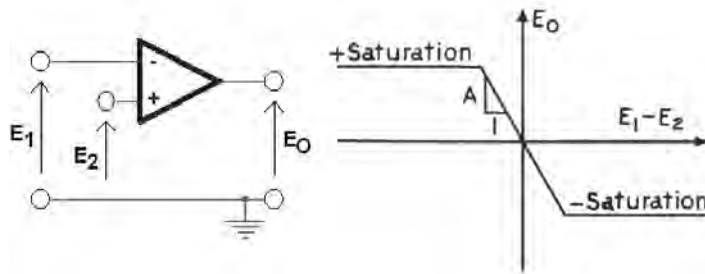

Figure 31. Input-Output Transfer Relation for the Open Loop Operational Amplifier

The open loop input-output relationship for a rather "well-behaved" practical operational amplifier is shown in figure 31. The open loop gain, A , is measured by the slope of the curve so it can be seen that the operational amplifier only amplifies between the saturation values of E_O .

The slope of the amplifying portion of the transfer curve is dependent on the frequency of the input voltage while the saturation voltages remain constant. This relation between input and output holds regardless of the feedback configuration used as long as the amplifier is not in overload.

The “well behaved” aspect of this operational amplifier is the fact that its transfer curve goes through the origin. In practice, all operational amplifiers exhibit offset, a fault that effectively shifts the transfer curve from the origin. To complicate matters further, this offset value will wander, producing drift. Both of these phenomena are of the same order of magnitude as the input voltage necessary to drive the open loop amplifier into saturation and a necessary part of circuit design is to minimize their effect.

Open Loop Operation

As an example of open loop operation, consider the Texas Instruments THS4001 used as an open loop DC amplifier. DC open loop gain is 10000 and output saturation occurs at ± 13.5 volts (for a supply voltage of ± 15 V). Hence, for linear operation, the input voltage cannot exceed $10,000 \times 2.7$ millivolts. The open loop amplifier is also subject to the full effect of random noise, offset, and drift, which may be greater than 2.7 millivolts. Therefore, the open loop amplifier is not useful for linear operation, because any circuit that is so close to saturation may cause the output to latch-up.

Output Limiting

Texas Instruments specifications for operational amplifiers give a voltage and a current output rating, plus output short circuit current. Output saturation voltages are commonly slightly greater than the rated output value when the nominally specified power supply voltage is used. Texas Instruments operational amplifiers will supply full output voltage to a load drawing full rated output current for an indefinite period.

In addition, for lower output voltages, slightly higher output current is available up to the short circuit conditions. Though the current ratings are conservative, exceeding the rated current should be attempted only after some calculation, unless the output voltage is extremely low. Output voltage is self-limiting, and voltage levels above the saturation voltage cannot be achieved. It is not recommended to operate an operational amplifier saturated for an indefinite period of time.

FREQUENCY DEPENDENT PROPERTIES

Introduction

The AC response characteristics of the operational amplifier are very important considerations in circuit design. DC operational amplifiers will operate successfully at audio, ultrasonic, and radio frequencies with some predictable variation from DC operation. Circuits designed to operate at DC are also affected by the AC response since random noise and varying DC levels contain AC components.

Open Loop Gain and the Bode Plot

The frequency response curve of operational amplifier circuitry is conveniently represented by the Bode plot. The absolute value of voltage gain is plotted in dB (the hybrid but popular

“decibel” defined by $\text{dB} = 20 \log \frac{E_o}{E_i}$ so that a gain of 10 is 20 dB, a gain of 100 is 40 dB, etc.)

versus the orthodox decade logarithmic frequency scale. The Bode plot of a typical operational amplifier’s open loop gain is shown in figure 32 along with a convenient linear approximation to the actual curve.

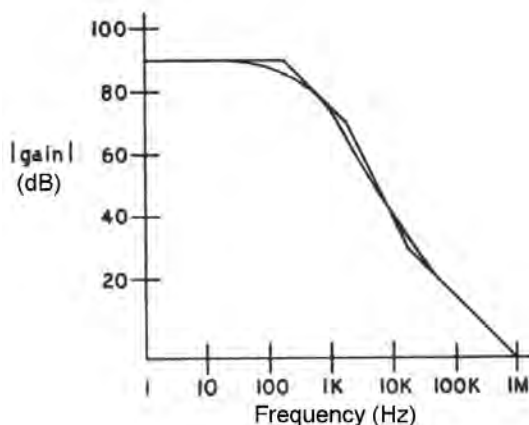

Figure 32. Bode Plot of an Operational Amplifier and its Linear Approximation

Bode Plot Construction

The shape of the Bode plot shown in figure 32 is characteristic of all compensated voltage feedback operational amplifiers. It is so characteristic, in fact, that any open loop Bode plot may be approximated rapidly from only two bits of information about the particular operational amplifier:

- 1) DC open loop gain
- 2) The unity-gain crossover frequency (open loop bandwidth).

For example: An operational amplifier has DC open loop gain of 108 dB and open loop bandwidth of 1 MHz. From these two values, we can sketch the Bode plot as indicated in figure 33.

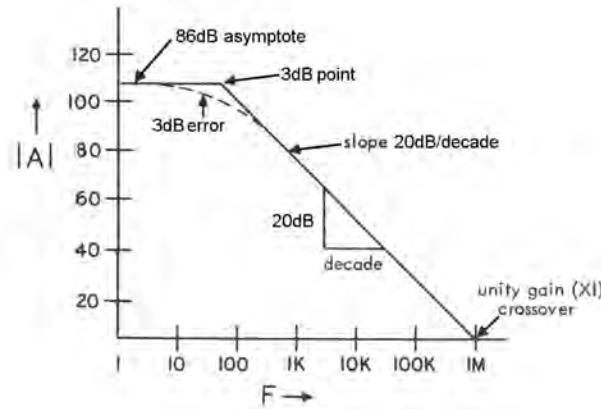

Figure 33. Sketching the Bode Plot Approximation for Figure 32

Comparing the shape of this sketch with the typical response of figure 32, the constant gain bandwidth product sketch is observed to be a conservative approximation to the typical response. Since the typical gain fall off exceeds 20 dB per decade at some points, there may be slight peaking at intermediate closed loop gains. Such peaks do not indicate a condition of instability.

Closed Loop Gain

When feedback is used around an operational amplifier, the closed loop gain of the circuit is determined by a ratio involving the input and feedback impedances used. If the closed loop gain called for by the feedback configuration is greater than the open loop gain available from the operational amplifier for any particular frequency, closed loop gain will be limited to the open loop gain value. Thus a plot of the closed loop gain of a X100 (40db) amplifier using the amplifier of figure 33 would appear as in figure 34:

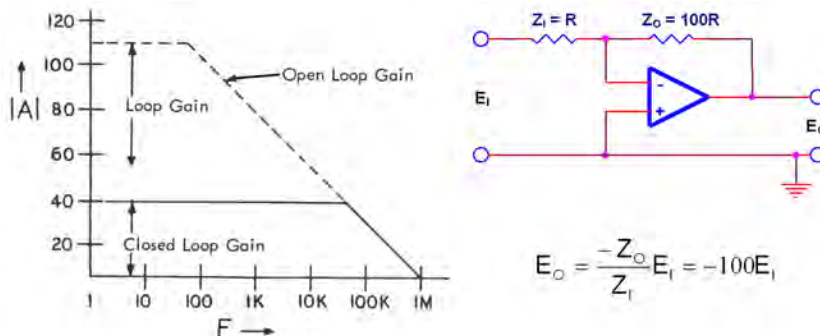

Figure 34. Closed Loop Gain of a X100 (40 dB) Inverting Amplifier

Stability

As indicated above, the closed loop amplifier circuit cannot supply more gain than is available from the operational amplifier itself, so at high frequencies, the closed loop Bode plot intersects and follows the open loop gain curve. The intersection point between the closed and open loop curves is important because the angle between the two curves - or, more precisely, the “rate of closure” since the curves aren’t actually straight lines - determines whether the closed loop amplifier, differentiator, etc., being designed will be stable. Principle: If the rate of closure between the open and closed loop sections of the Bode plot is greater than 40 db per decade the system is likely to be unstable. Bode plots may be varied almost at will to insure stability or to provide some tailor made frequency response characteristic.

Compensation

The open loop gain of operational amplifiers is tailored or “compensated” with one or more simple resistor and capacitor combinations (figure 35).

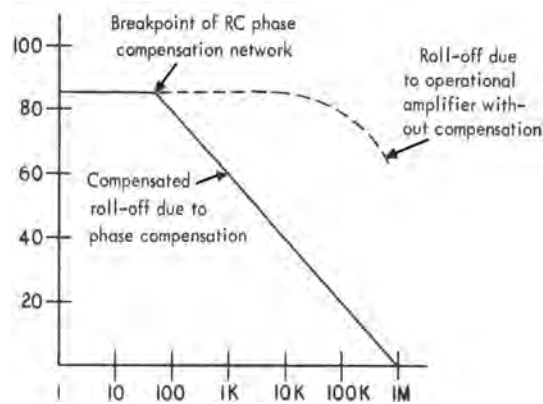

Figure 35. The Effect of Internal Phase Compensation

Phase compensation is effected in order that the majority of popular circuits utilizing operational amplifiers will be inherently stable, even under conditions of 100% feedback. As a consequence of internal compensation, the user may connect feedback around the amplifier with relative impunity. We must hasten to add, though, that each feedback condition is, in essence, a special case. Superior results may be obtainable by adding external compensation. Knowledge of the stability criteria and the Bode plot will be adequate in all but the most unorthodox circuits.

If compensation were not provided, certain amplifier circuits would be unstable under normal operating conditions according to the above “rate of closure” or change of slope principle. The effect of compensation on closed loop stability can be seen from the Bode plots of figure 36, showing several different closed loop amplifiers utilizing the same operational amplifiers with and without compensation.

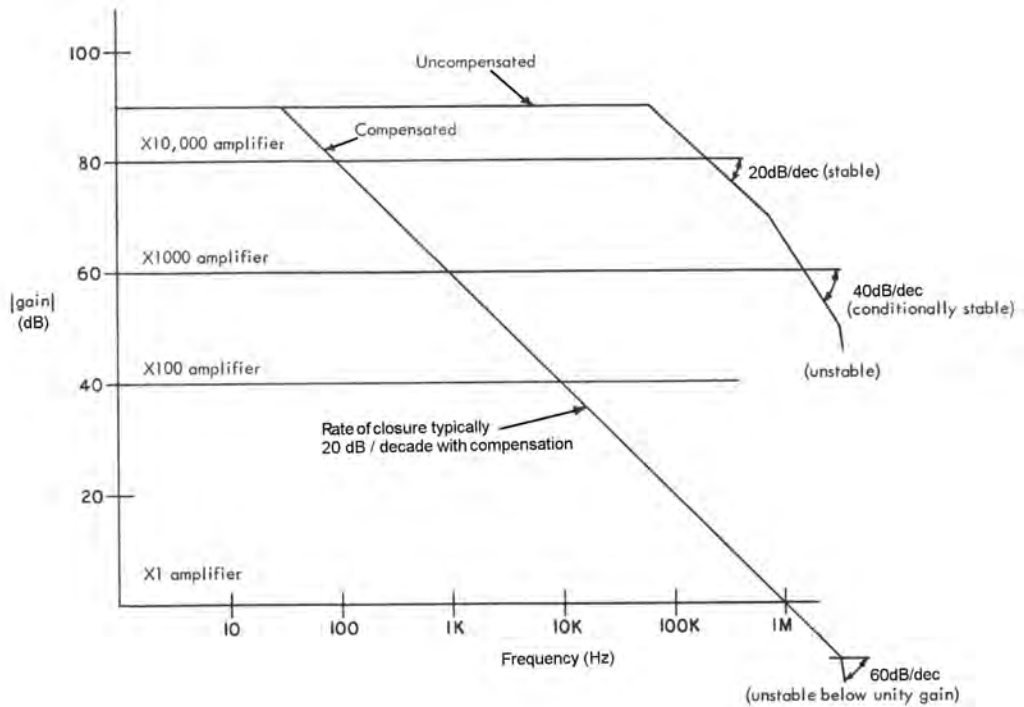

Figure 36. Composite Bode Plots Showing Stability Provided by Proper Phase Compensation

Compensation Changes

Operational amplifier compensation for most voltage feedback amplifiers is internal to the die, and cannot be changed. Texas Instruments supplies voltage feedback amplifiers that are compensated for gains higher than unity gain, and uncompensated operational amplifiers. The purpose of decreasing compensation, sacrificing unity gain stability, is to increase the flatness of the response curve the operational amplifier by changing the 3 dB breakpoint frequency. The effect of this is shown in figure 37.

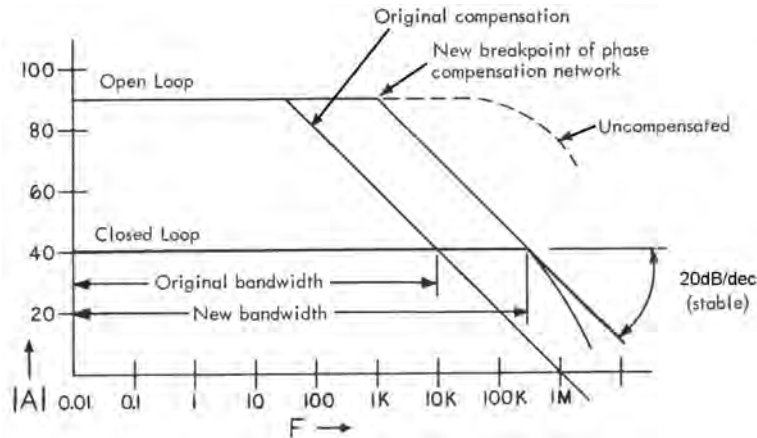

Figure 37. The Effect of Internal Compensation for Gains Greater Than 1

The amplifier can be used at gain levels above the designated gain level, as determined by external compensation and feedback components, but it cannot be used for lower gains without readjusting the compensation. Instability would result since the rate of closure may be too large at low gain values (figure 38).

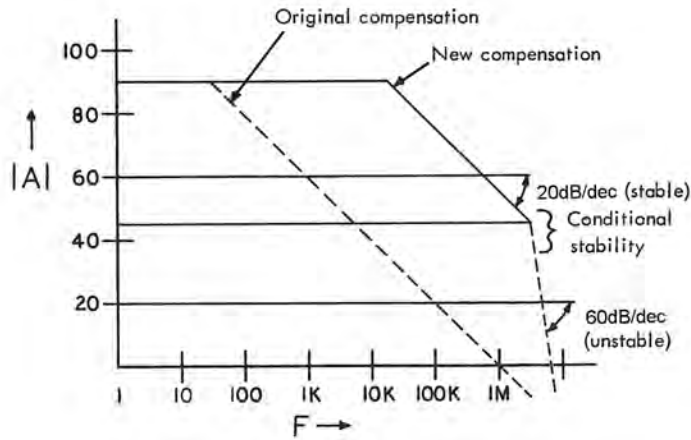

Figure 38. Instability when an Uncompensated Amplifier is Used at Gains Lower Than the Designated Level.

Bandwidth

The open loop bandwidth of the operational amplifier is shown explicitly in the Bode plot. The plot has only two distinguishing frequencies, one being the unity gain crossover frequency and the second being the 3 dB point. The 3 dB point is considered to be the bandwidth of the open loop amplifier and used in open loop specifications.

The unity gain crossover frequency may be from 100 kHz for signal amplifiers to 1 GHz or higher for high-speed amplifiers. An important aspect of bandwidth - besides making high frequency operational amplifier circuits practical - is to improve the precision of signal amplification. The loss of high frequency components of non-sinusoidal voltages such as pulses, control signals, DC steps, or even speech patterns may result in undesirable distortion and phase shift.

Wide bandwidth amplifiers are used maintain high loop gain at lower signal frequencies. For example, it is necessary to use an operational amplifier with open loop bandwidth of at least 200 MHz to provide a closed loop gain of 40 dB at 1 MHz.

Loop Gain

As indicated in figure 34, loop gain is the gain “difference” between open and closed loop gain. In actuality, the loop gain is the ratio between open loop gain and closed loop gain since subtracting on the logarithmic gain scale is equivalent to division.

$$\text{Loop Gain} = \frac{\text{Open Loop Gain}}{\text{Closed Loop Gain}}$$

In a practical circuit, loop gain is the increase in gain that is observed when the feedback path is opened, but with all circuit loads intact. Loading effects of finite input and output impedance, as well as the external feedback components, will lead to reduced loop gain. For example, in a unity gain inverting configuration, 6 dB is lost due to the voltage divider effect of the input and feedback resistors. Since the phase compensation network fixes the 3 dB point and roll off rate of the frequency response, the reduced gain effectively lowers the bandwidth. An inspection of figure 39 will clarify this effect.

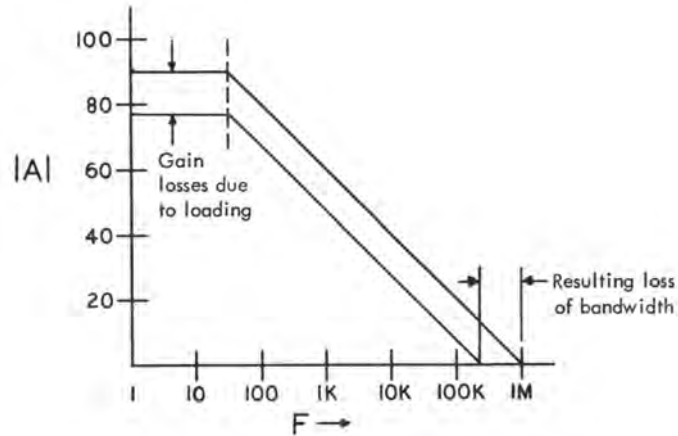

Figure 39. Loss of High Frequency Response When Heavy Feedback is Used

The Significance of Loop Gain

Just as local degeneration around a transistor can reduce circuit sensitivity to certain parameter changes in that transistor, feedback around an operational amplifier will reduce sensitivity to open loop parameter changes. Open loop gain, phase shift, input impedance, and output impedance may vary with temperature, power supply voltage, and time. Loop gain is the payment made for circuit stability and gain accuracy, and it is a direct measure of the improvement obtained. Basic stability, however, must be designed into the open loop amplifier.

Noise, drift, and offset will not be affected by loop gain. These parameters are essentially input functions that, like the signal, will be increased by the closed loop gain. The signal to noise ratio will remain constant, independent of gain. Loop gain will improve closed loop gain stability, phase shift, input impedance, and output impedance.

BODE PLOTS AND BASIC PRACTICAL CIRCUITRY

Voltage Follower

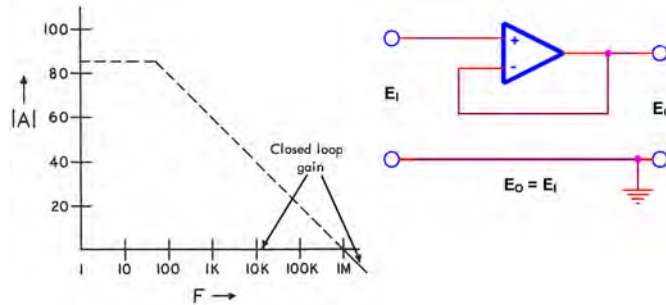

Figure 40. Voltage Follower Circuit

The unity gain follower and its Bode plot are shown in figure 40. Since there is no feedback impedance loading, the closed loop plot traces out the unity gain line to the open loop unity gain crossover before rolling off.

Inverter

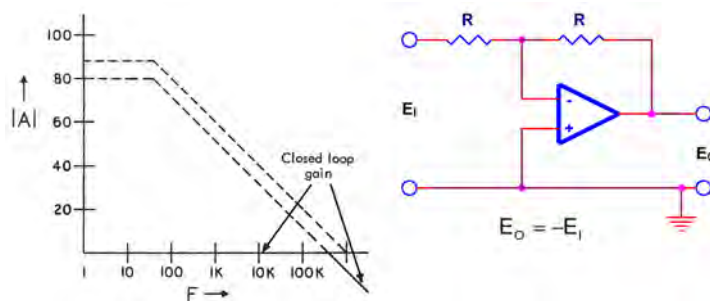

Figure 41. Voltage Inverter Circuit

A unity gain inverting amplifier is shown in figure 41. The bandwidth is decreased by one octave (50%) from that of the voltage follower due to the voltage division effect of the input and feedback resistors mentioned above.

X1000 Amplifier

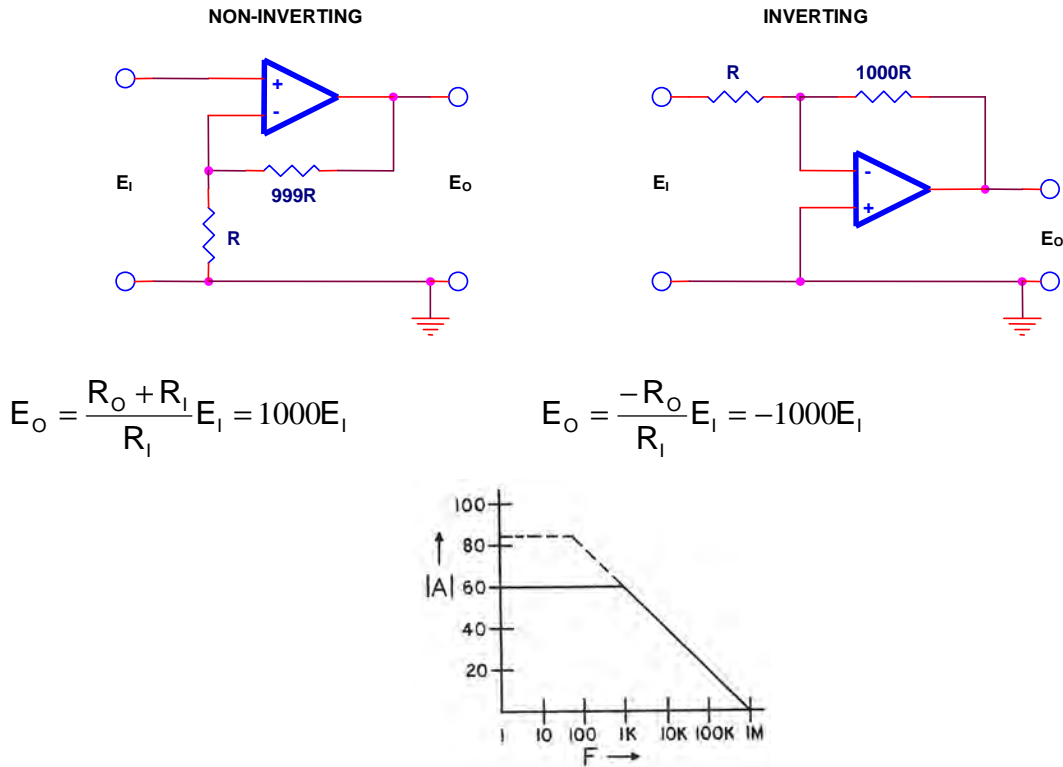

Figure 42. 60 dB Amplifier Circuits

Figure 42 shows the Bode plot for either the inverting or non-inverting amplifier with a gain of X1000 (60db). Negligible bandwidth is last due to the voltage divider effect but is still very much reduced by the normal roll off of the open loop curve.

Differentiator

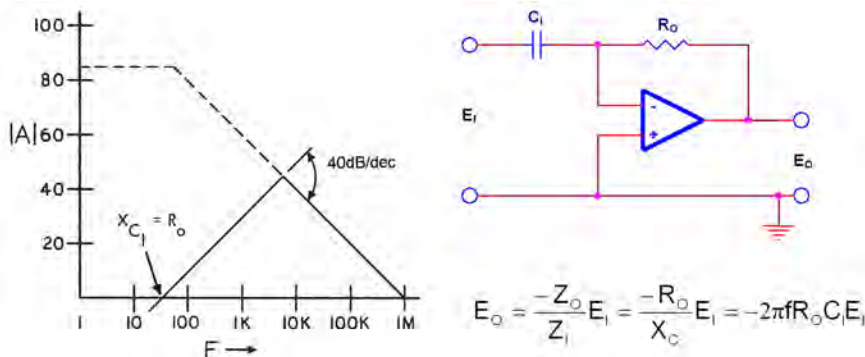

Figure 43. Differentiator Circuit

The Bode plot of the differentiator (figure 43) is slightly more trouble to construct since the Z_i value is dependent on frequency. It is evident that the curve must intersect the unity gain axis at the frequency where $X_C = R_o$ (conveniently found from the reactance chart in Appendix A). For DC, the capacitor represents infinite impedance hence gain is zero. At higher frequencies, X_C drops and the gain increases, which is approximated closely by a straight line rising at 20 dB / decade.

Since highest gain is encountered at high frequencies, this circuit is very susceptible to random noise. Even more important, however, is the fact that the rate of closure is about 40 dB / decade, making the simple differentiator inherently unstable in operation. One practical method of reducing noise and preventing instability is shown in figure 44.

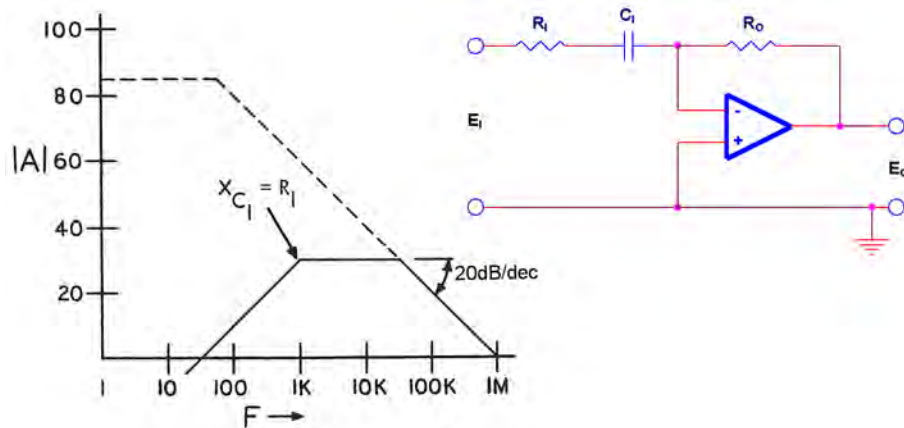

Figure 44. Differentiator With “Stop”

At high frequencies, X_C is negligible and the circuit operates as an amplifier with resistive feedback. The transition “point” is the frequency at which $f = \frac{1}{2\pi R_i C_1}$. Note that a capacitor, C_o , in parallel with R_o would have produced the same results with the significant frequency given by $f = \frac{1}{2\pi R_o C_o}$.

Both techniques may be combined to give even better noise rejection (figure 45).

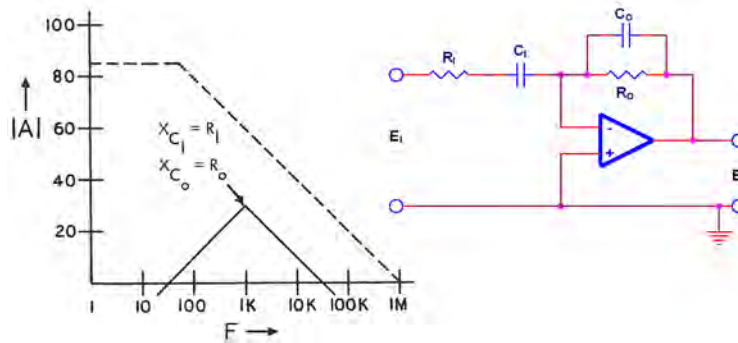

Figure 45. Differentiator With “Double Stop”

With R_o and C_o set to break at the same frequency as R_i and C_i , the total slope change will be twice that of a single RC combination, hence a roll off of 20 dB / decade is introduced.

INTEGRATOR

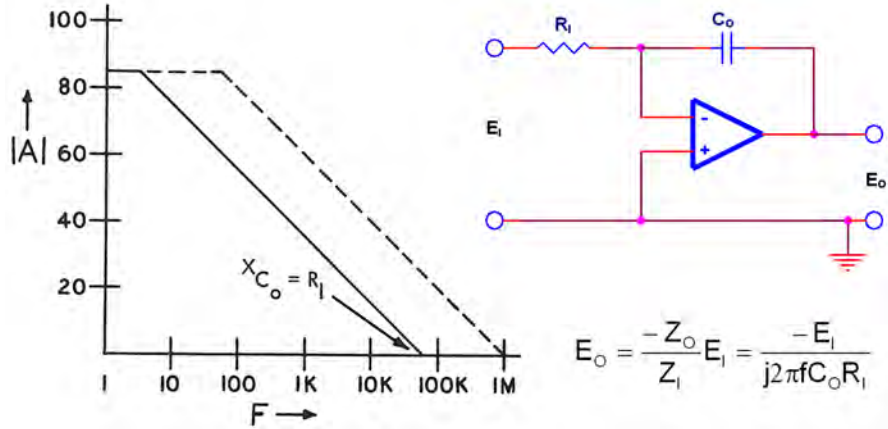

Figure 46. Integrator Circuit

The discussion above should make the Bode plot for an integrator simple to deduce (figure 46). Unity gain crossover occurs at the frequency where $X_{C_o} = R_i$. The slope is a negative 20 dB / decade and gain would ideally go to infinity at DC.

OTHER IMPORTANT PROPERTIES OF OPERATIONAL AMPLIFIERS

Summing Point Restraints

In the case of the ideal operational amplifier, circuit analysis was simplified by the ideal summing point restraints of zero voltage and zero current at the inverting input. The real operational amplifier summing junction comes close to this, as will be shown in an example.

A typical Texas Instruments THS4001 Operational Amplifier has a DC open loop gain of 80 dB or 10,000, open loop input impedance of 10 MΩ, and a saturation voltage of more than ±13 volts.

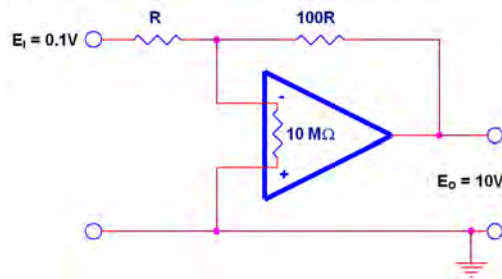

Figure 47. DC Summing Point Conditions

For the circuit shown in figure 47 to have a full output of 10 volts, the voltage at the inverting input must be:

$$E_- = \frac{10}{10,000} = 1 \text{ mV}$$

The current flowing to the inverting input is the voltage at the inverting input divided by the impedance to the non-inverting input, which is r_i . This specification is available from the data sheet.

$$I_- = \frac{1 \text{ mV}}{10 \text{ M}\Omega} = 0.1 \text{ nA}$$

Note that these calculations do not depend on the values of the feedback and input elements. In fact, they don't depend on the nature of the closed loop circuit at all, so long as the operational amplifier is not operating in an overload condition.

Since the dynamic voltage current variations that appear at the summing junction of a real operational amplifier in a closed loop circuit are so small, they are considered zero - as in the ideal case - for circuit analysis purposes. It must be noted, however, that this effect is due to the high open loop gain of the operational amplifier. At high frequencies, the open loop gain falls off and the summing point voltage and current increases accordingly for the same output. Also, the static effects of input voltage and current offset as well as drift must be taken into account. These will be discussed more fully later.

Closed Loop Impedance Levels

Open loop output impedances are given in the specifications and range from 3 Ω to 5000 Ω , with the majority of operational amplifiers having 100 or 200 Ω open loop output impedance. Since the input and feedback resistors usually will vary from 1 k Ω to 1 M Ω , this may represent a rather poor approximation of the ideal zero output impedance. However, as we shall see, the equivalent closed loop output impedance is typically less than an ohm.

Open loop input impedances are also specified and run as high as 10¹⁵ Ω . Compared to the typical feedback impedance levels, this can be a very good approximation of the ideally infinite, open loop input impedance. Practically, this is of little importance since the input resistor determines the closed loop input impedance of the inverting amplifier. Calculations will show that the equivalent input impedance of the non-inverting amplifier may be hundreds or thousands of M Ω , closed loop.

Output Impedance

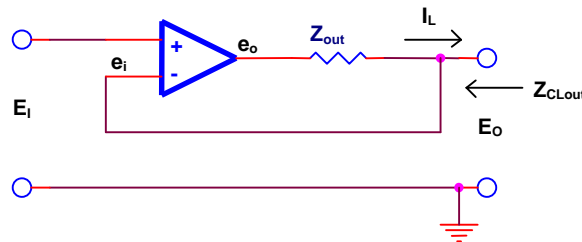

Figure 48. Voltage Follower

Using the Texas Instruments THS4001 as a voltage follower in the circuit of figure 48, we can readily determine the effective closed loop output impedance. Loading this circuit with an incremental output current, ΔI_L , forces the amplifier output, e_o , to increase by:

$$\Delta e_o = \Delta I_L Z_{out}$$

To maintain this Δe_o , the voltage across the inputs must change by:

$$\frac{\Delta e_o}{A}$$

Since the inverting input is tied to the output and the input voltage, E_i , applied to the non-inverting input, must decrease by Δe_i . The effective output impedance is then seen to be:

$$\frac{\Delta E_o}{\Delta I_L} = \left(\frac{\Delta e_o}{A} \right) \left(\frac{Z_{out}}{\Delta e_o} \right) = \frac{Z_{out}}{A}$$

Thus, for the THS4001, the open loop output impedance of 10 Ω is decreased by the DC gain of 10,000 to an effective 0.001 Ω at the output plus any lead impedance between the feedback point and the load.

More general calculations would show that the output impedance is reduced by the loop gain. The voltage follower is a limiting case in which the loop gain is equal to the open loop gain.

Input Impedance

Closed loop input impedance is also increased by loop gain in non-inverting closed loop applications. In the inverting or summing closed loop configuration, the summing junction is a virtual ground and the input impedance is almost exactly the value of the summing impedance, Z_i .

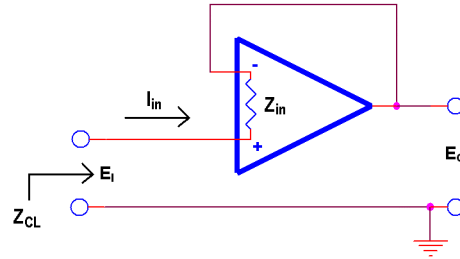

Figure 49. Voltage Follower

In figure 49, the operational amplifier is again shown in the voltage follower circuit with the open loop input impedance Z_{in} , indicated. For any change in output voltage, ΔE_o , the voltage across the inverting and non-inverting input must change by ΔE_o divided by the open loop gain, A :

$$\Delta e_i = \frac{\Delta E_o}{A} = \frac{\Delta E_1}{A}$$

The change of voltage, Δe_i , across the open loop input impedance, Z_{in} , demands a current, ΔI_{in} , equal to Δe_i divided by Z_{in} .

$$\Delta I_{in} = \frac{\Delta e_i}{Z_{in}} = \frac{\Delta E_2}{AZ_{in}}$$

The closed loop input impedance, $Z_{CL\ in}$, is the change in input voltage, ΔE_2 , divided by the change in input current, ΔI_{in} .

$$Z_{CL\ in} = \frac{\Delta E_2}{\Delta I_{in}} = \Delta E_2 \left(\frac{AZ_{in}}{\Delta E_2} \right) = AZ_{in}$$

Again, this is a limiting case in which the loop gain is equal to the open loop gain. In the more general case, the effective input impedance is equal to the open loop input impedance multiplied by the loop gain. Thus, assuming zero offset currents, the input impedance of the THS4001 is greater than 10 M Ω as long as loop gain is greater than 40 dB. Current leakage paths associated with the input stage tend to limit the input impedance to be achieved in this manner to about 10 M Ω .

Differential Inputs and Common Mode Rejection

The input to most Texas Instruments operational amplifiers is a pair of input pins, neither of which is connected to ground. Such pair of “floating” input connections is termed “differential inputs”. Each input connection drives separate, balanced transistor amplifiers. Ideally, the same voltage connected to each input would produce no net result; hence the operational amplifier would only detect the difference in the two input voltages. The voltage that both inputs experience is known as the common mode voltage.

In practice, the voltages on each input are amplified separately and, due to component variations, never perfectly balance out to zero. The “common mode rejection” property of a differential input amplifier also depends on the feedback configuration of the closed loop application.

The Common Mode Voltage Limit

As stated above, the circuitry within the operational amplifier responds to the voltages appearing at the two inputs separately. Either input can be overdriven, saturating the input transistor(s). Since under normal feedback conditions there is only a negligible difference in voltage between the two inputs (see “Summing Point Restraints”), the input saturation voltage is known as the common mode voltage limit and appears in Texas Instruments specifications.

For the inverting amplifier, one input terminal is grounded; hence, the common mode input voltage is zero. In the non-inverting configuration, however, an equal voltage appears at both input terminals and the common mode limit must be observed.

Offset

It was mentioned earlier that a certain input voltage is necessary to balance the operational amplifier circuit. This input voltage is needed because of a small bias current and voltage inherently required by the operational amplifier, called offset. When these two bias components are not externally supplied, they are drawn from the input and feedback networks causing an output voltage error.

In most applications, this small error is negligible. For highest performance, simple biasing circuits may be used externally. As an example, a simple bias current injector as shown in figure 50 may correct the current components of input offset.

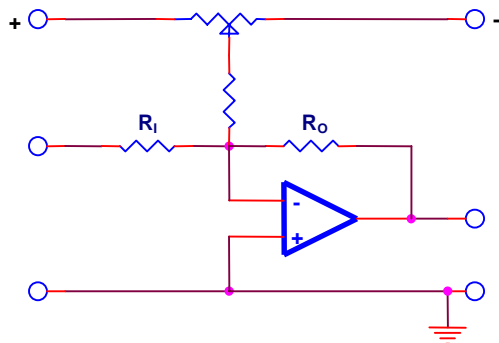

Figure 50. Inverting Amplifier with Current Offset Control

Drift

The bias values mentioned above will vary with temperature, time, and power supply voltage, producing a variable output error or drift. Again, this effect is negligible in many cases, but it should be taken into account in critical applications.

In some Texas Instruments operational Amplifiers, input connections are made directly to the bases of a matched pair of input transistors. Thus, variations in base current and emitter to base voltage caused by external changes, i.e. temperature, will tend to cause both input transistors to vary in the same direction. Since the base currents must flow to ground through the external feedback network, drift effects can be minimized by: (1) using the lowest resistance levels consistent with input impedance requirements and output current capability; and (2) balancing the resistances from the two inputs to ground. For the amplifier shown in figure 51, this latter consideration is satisfied by connecting a resistor from the non-inverting input to ground equal to the equivalent resistance from the inverting input to ground.

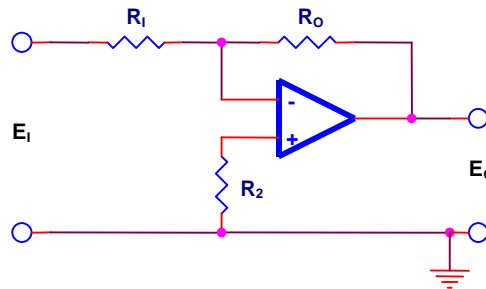

Figure 51. Drift Stabilizing the Inverting Amplifier

Capacitive Loading

The addition of capacitive reactance shunting the load of an operational amplifier may lead to peaking and finally instability at high frequencies. The capacitive load tends to break with the output impedance of the amplifier causing the slope of the open loop response to increase. As the rate of closure approaches 40 dB / decade (see "Stability" above), the closed loop response begins to peak and possibly oscillate (figure 52). This problem is most severe at low gain levels and at high frequencies.

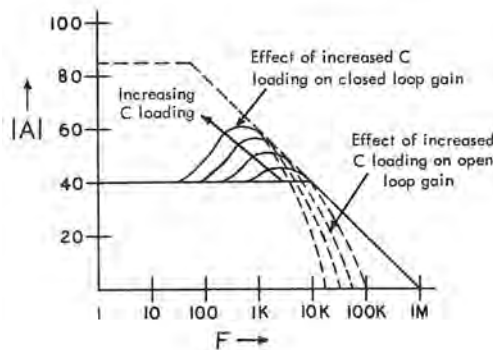

Figure 52. Gain Peaking Caused by Capacitive Loading

VOLTAGE DETECTORS AND COMPARATORS

When this handbook was first published, there were no comparators. Operational amplifiers were used in a saturated mode as comparators. This section covered the use of operational amplifiers as comparators, but Texas Instruments strongly discourages this practice. Reference 1 covers this topic in more detail.

When an operational amplifier absolutely must be used as a comparator, there are a couple of alternatives:

Voltage Limiting Operational Amplifiers

Texas Instruments manufactures voltage limiting operational amplifiers that are specifically designed to operate at saturated levels, as set by voltage limiting inputs:

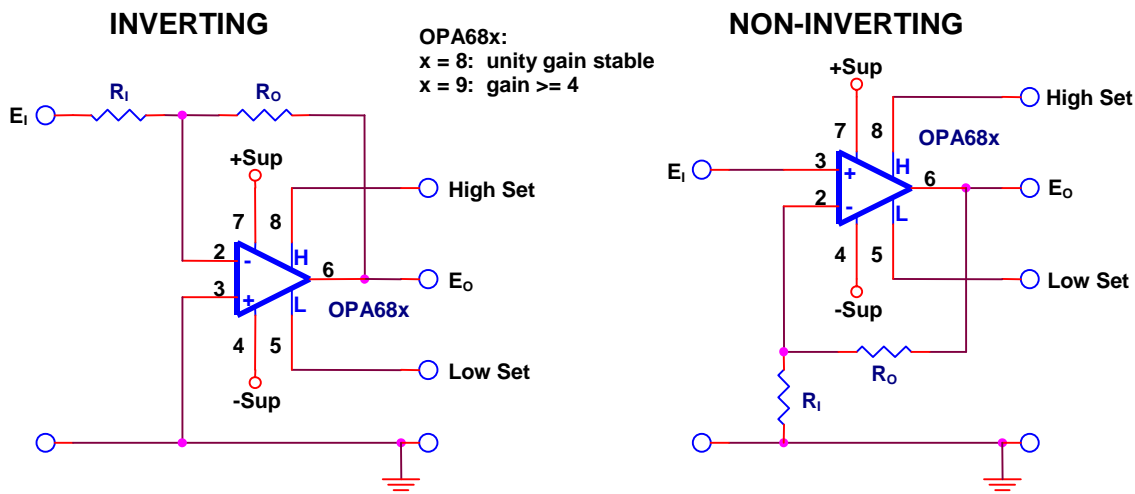

Figure 53. Voltage Limiting Operational Amplifiers

Voltage limiting operational amplifiers are popular in applications that require clipping, such as video “sync-stripping” circuits. The High Set and Low Set inputs are used to set the maximum V_{OH} and V_{OL} of the op amp to values between $\pm Sup$. There is no reason why the High Set and Low Set values have to be positive and negative voltages, respectively. They can be at ground, or beyond it. There are limits, of course. The amplifier itself has V_{OH} and V_{OL} specifications that ultimately limit the set levels. The set levels also have a specified accuracy. Incorrect set level voltages can also prevent the output from working at all. Consult the data sheets for details.

It is possible to use an operational amplifier with external components simulating the output clamping circuits fabricated into the voltage limiting operational amplifiers described above. Figure 54 shows an example of the technique:

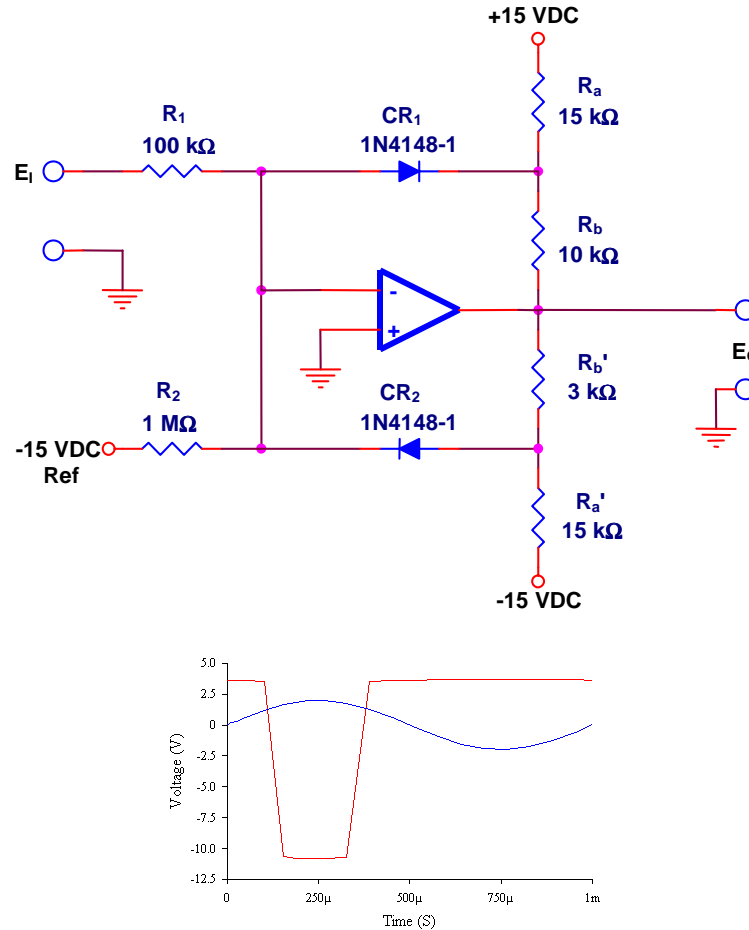

Figure 54. Fully Clamped Voltage Comparator

$$\text{Threshold} = -\frac{R_2}{R_1} V_{\text{ref}} = -\frac{1 \text{ M}\Omega}{100 \text{ k}\Omega} (-15 \text{ VDC}) = 1.5 \text{ VDC}$$

$$\text{Negative clamping level} = \frac{-(+V_{\text{sup}})R_b}{R_a} = \frac{-15 \text{ VDC} \cdot 10 \text{ k}\Omega}{15 \text{ k}\Omega} = -10 \text{ VDC}$$

$$\text{Positive clamping level} = \frac{-(-V_{\text{sup}})R_b}{R_a} = \frac{+15 \text{ VDC} \cdot 3 \text{ k}\Omega}{15 \text{ k}\Omega} = +3 \text{ VDC}$$

$$E_o = -10 \text{ VDC for } E_i > 1.5 \text{ VDC}$$

$$E_o = +3 \text{ VDC for } E_i < 1.5 \text{ VDC}$$

The slope of the transition is determined by the slew rate of the operational amplifier. The set points, of course, must be within the normal V_{OH} and V_{OL} of the operational amplifier.

SECTION II CIRCUIT COLLECTION

A search of literature in the field and Texas Instrument's collection of application notes turned up the circuits presented in this section. They have been grouped by general function and ordered within each group by increasing complexity. It is our hope that one of these will trigger the idea that develops into your circuit.

Please do not interpret any one circuit as our recommendation for your requirement. Some of them, due to their simplicity or specialized nature, may perform only over limited ranges and under controlled conditions. We would welcome the opportunity to suggest a specific circuit for you, given the details of your application.

THE VOLTAGE FOLLOWER

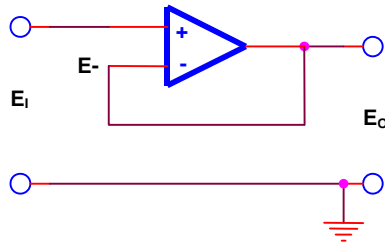

Let the voltage at the inverting input with respect to the non-inverting input be E_- .

By Kirchoff's voltage law:

$$(E_-) + E_i = E_o$$

But by definition:

$$E_o = -A(E_-)$$

where A is the gain of the operational amplifier

Then:

$$(E_-) = \frac{-E_o}{A}$$

And substituting:

$$E_i - \frac{E_o}{A} = E_o$$

Letting A go to infinity, $\frac{E_o}{A}$ approaches zero, and:

$$E_o = E_i$$

BUFFERS AND ISOLATION AMPLIFIERS

The standard inverting and non-inverting amplifier circuits provide impedance isolation due to their inherently low equivalent output impedance. The following circuits are designed principally for isolation and not for providing gain.

Inverting Buffer Adjustable Gain

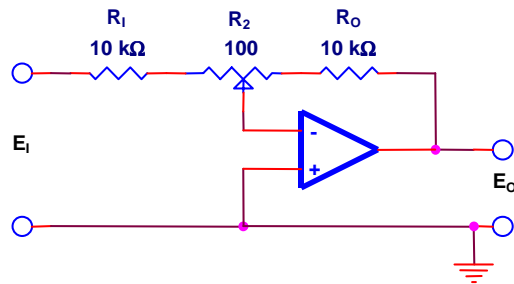

Potentiometer in feedback allows gain trimming to compensate for tolerance in resistor values.

Balanced Output

Used for driving balanced loads or push-pull stages when ground reference is critical.

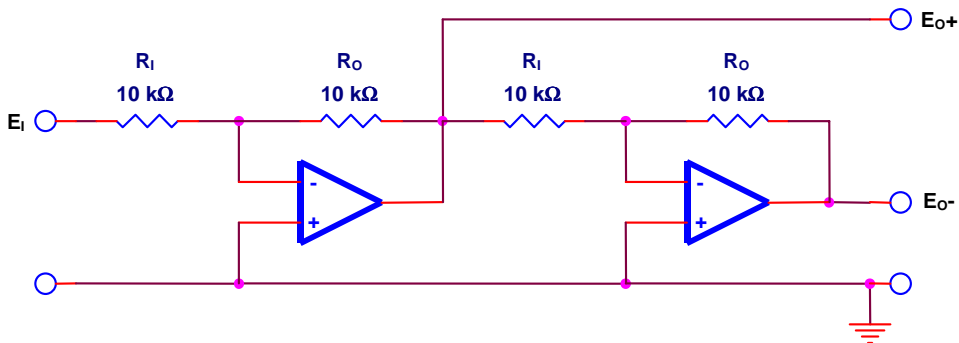

By using E_{O-} terminal at the reference, a p-p swing of $4E_i$ is obtainable at E_{O+} , i.e. a usable swing greater than the power supply voltage rails. A fully differential operational amplifier provides this function in a single package, and is therefore the preferable design solution.

VOLTAGE AND CURRENT REFERENCES

The high input impedance and low output impedance levels that can be obtained with the precision and stability of operational amplifier circuitry make reference supplies practical. Some circuits are merely reference cells or zener diodes with isolator and multiplying circuits added.

Isolated Standard Cell

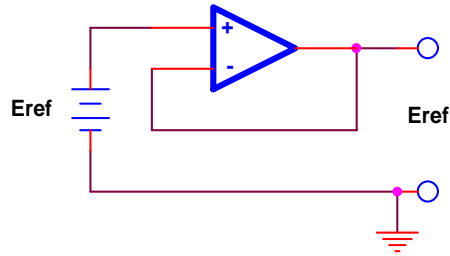

Prevent damage to standard cells induced by drawing current from them with low impedance (20 K Ω / Volt) measuring devices. See section on Buffers and Isolators for gain error. Offset adjustments should not be made with standard cell connected.

Constant Current Generator

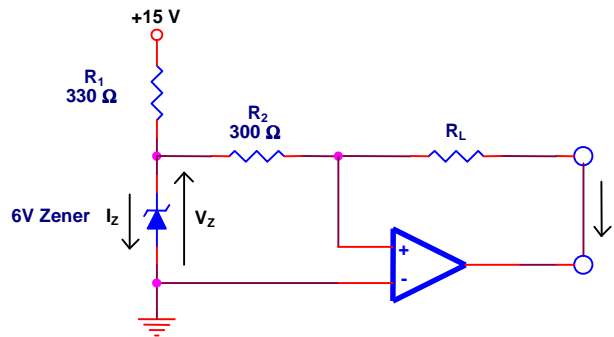

Convenient current reference up to 20 mA:

$$I = \frac{V_Z}{R_2} = \frac{6}{300} = 20 \text{ mA}$$

$$R_1 = \frac{15 - V_Z}{I_Z} = \frac{9}{25} = 360 \text{ } \Omega$$

$$R_{L \text{ min}} = \frac{\text{Saturation Voltage}}{I} = \frac{13.5 \text{ V}}{20 \text{ mA}} = 675 \text{ } \Omega$$

Buffer Variation

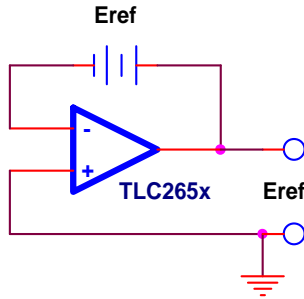

Low current drift of chopper - stabilized amplifiers improves stability and cell protection.

Pre-settable Voltage Source

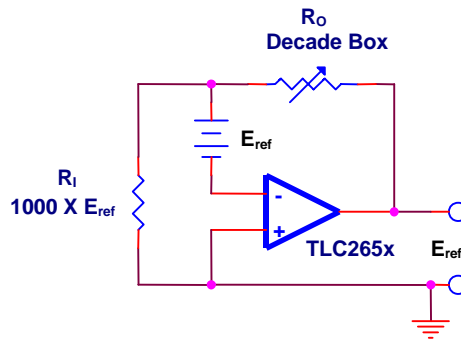

$$E_o = \frac{R_1 + R_o}{R_1} E_{ref}$$

Gives wide range of very stable reference voltages.

Reference Voltage Supply

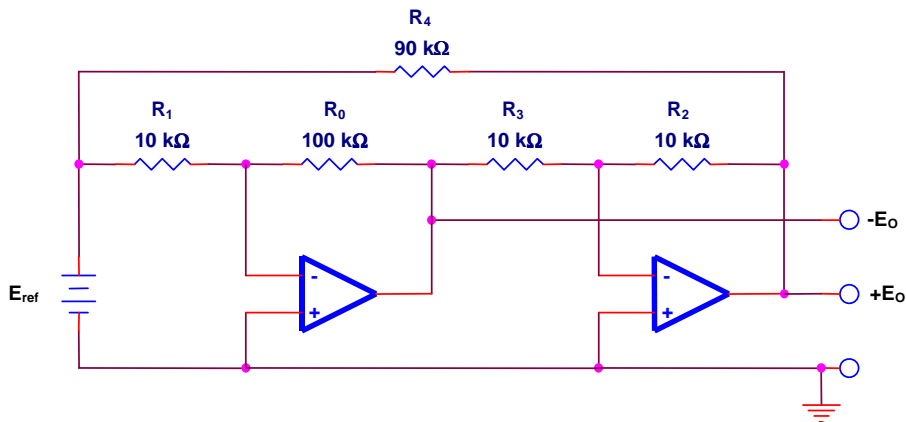

THE NON-INVERTING AMPLIFIER

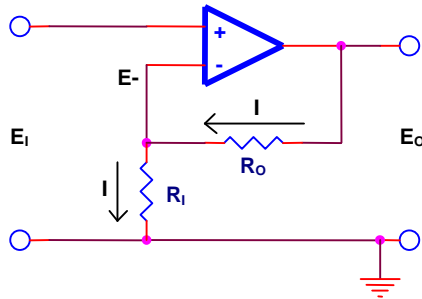

Let the voltage at the inverting input with respect to the non-inverting input be E_- and the gain of the operational amplifier be A (ideally, $A = \infty$).

The voltage at the inverting input is then $E_i + (E_-)$ and, since the current in R_i must equal the current in R_o :

$$\frac{(E_-) + E_i}{R_i} = \frac{E_o - ((E_-) + E_i)}{R_o}$$

but:

$$E_o = -A \cdot (E_-)$$

$$(E_-) = \frac{-E_o}{A}$$

Letting A go to infinity, E_- approaches zero and the first equation becomes:

$$\frac{E_i}{R_i} = \frac{E_o - E_i}{R_o}$$

Solving:

$$E_i(R_o + R_i) = E_o R_i$$

$$\frac{E_o}{E_i} = \frac{R_o + R_i}{R_i} = 1 + \frac{R_o}{R_i}$$

THE INVERTING AMPLIFIER

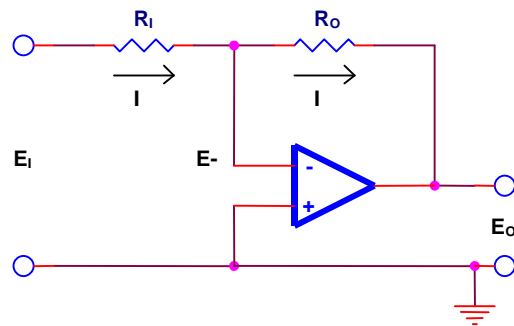

Let the voltage at the inverting input be E_- and the open loop operational amplifier gain be A (ideally, $A = \infty$).

Since equal currents flow in R_o and R_i :

$$\frac{E_i - (E_-)}{R_i} + \frac{E_o - (E_-)}{R_o} = 0$$

But by definition:

$$E_o = A \cdot (E_-)$$

$$(E_-) = -\frac{E_o}{A}$$

Letting A go to infinity, E_- approaches zero and:

$$\frac{E_i}{R_i} + \frac{E_o}{R_o} = 0$$

or:

$$\frac{E_o}{E_i} = -\frac{R_o}{R_i}$$

INTEGRATORS

Assume the validity of the ideal gain expression for the generalized Inverting Amplifier:

$$E_o = \frac{-Z_o}{Z_i} E_i$$

The operational form of capacitive impedance is:

$$Z_c = \frac{1}{C_p}$$

where the symbol, p , is the operator, $\frac{d}{dt}$, or for AC analysis is the complex frequency, $j2\pi f$.

For the integrator;

$$Z_o = \frac{1}{C_p}, \quad Z_i = R_i$$

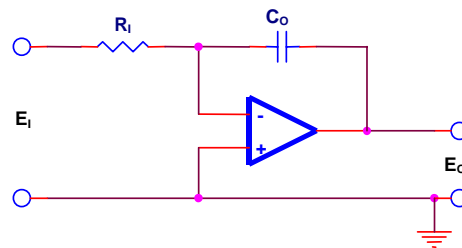

$$E_o = \frac{-Z_o}{Z_i} E_i = \frac{-E_i}{R_i C_o p} = -\frac{1}{R_i C_o} E_i dt$$

PRACTICAL INTEGRATORS

Simple integrator circuits operate successfully but current offset is stored in the feedback capacitor causing output voltage error. This is corrected with low drift chopper stabilized amplifier and/or current biasing networks.

Simple Integrators

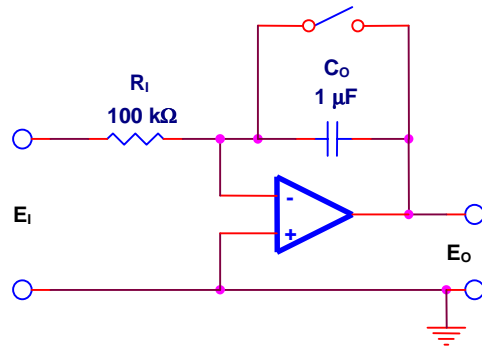

$$E_o = \frac{-E_i dt}{R_1 C_o} = -10 E_i dt$$

Close switch to reset to zero.

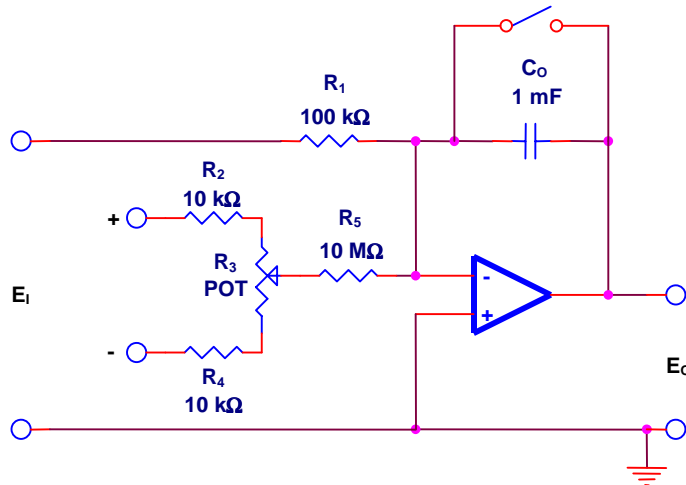

This circuit reduces current offset in operational amplifiers without “Balance” controls. With zero input and switch open, set R3 for zero output drift.

Regeneration may be used to increase open loop DC gain to infinity.

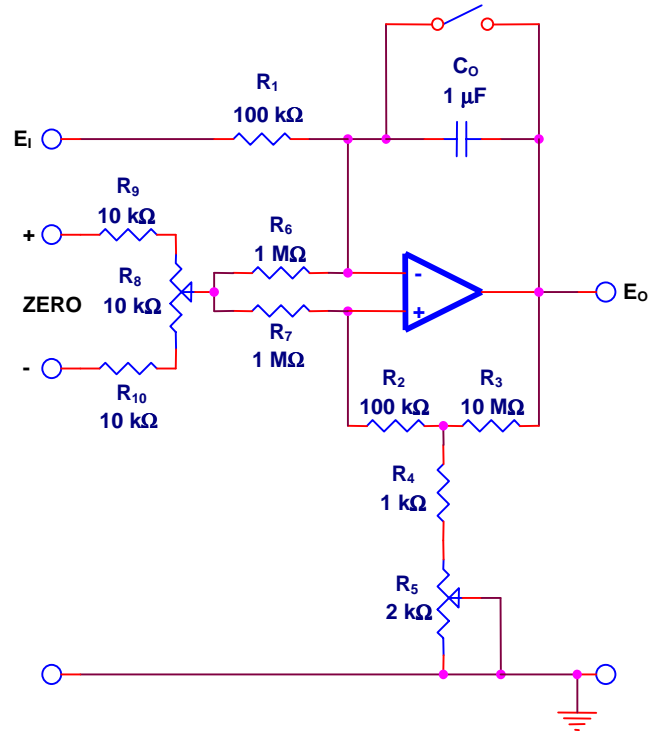

1. With input open and regeneration control R_5 in approximate center of its range, open reset switch and adjust zero control, R_8 , until output remains at zero.
2. Open reset switch, apply an input signal of either polarity and allow integrator to run up to some voltage between ± 10 VDC, then open circuit signal input.
3. If integrator output decays toward zero, increase regeneration by increasing R_5 . If output continues to grow, decrease regeneration.
4. If setting of regeneration control is altered, repeat steps (1) and (2) above.

Summing Integrator

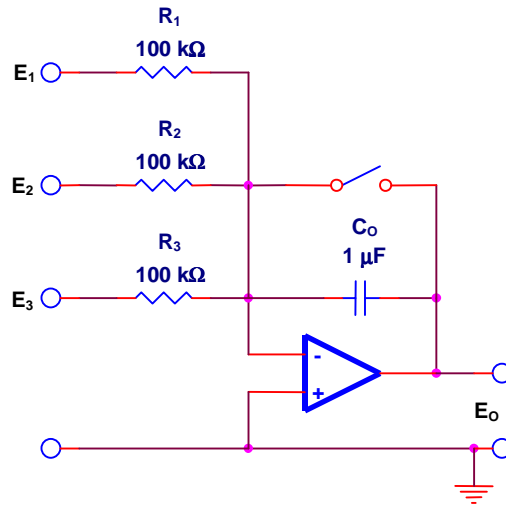

$$E_o = \frac{-1}{RC} (E_1 + E_2 + E_3) dt$$

$$= -10 (E_1 + E_2 + E_3) dt$$

One amplifier replaces separate summer and integrator circuits. Any number of inputs may be used. Zero control and regeneration may be added as in the above circuit.

Double Integrator

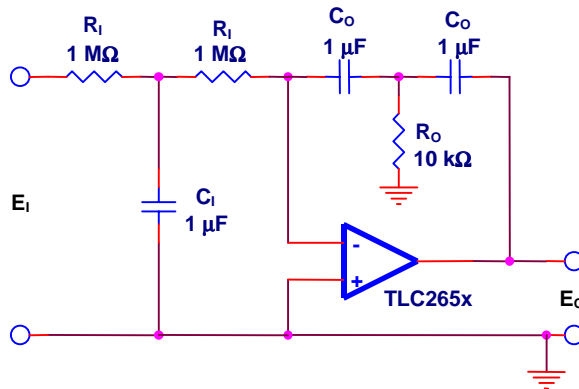

$$E_o = \frac{-4}{(R_1 C_1)^2} E_i dt = -4 E_i dt$$

where :

$$C_o = \frac{C_1}{2}, R_o = \frac{R_1}{2}$$

Integrates twice with one amplifier.

Differential Integrator

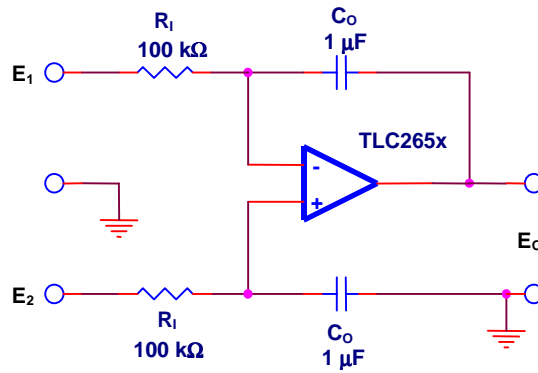

$$E_o = \frac{-1}{R_1 C_o} (E_1 - E_2) dt$$

$$= 10 (E_2 - E_1) dt$$

Integrates difference between two signals.

AC Integrator

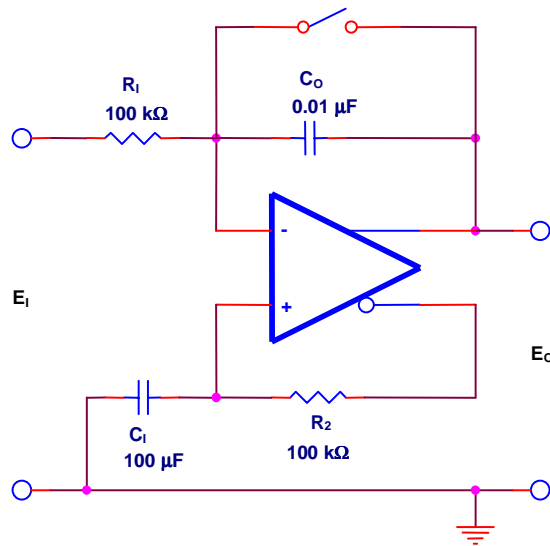

Integrates AC component only.

Augmenting Integrator

Sums the input signal and its time integral.

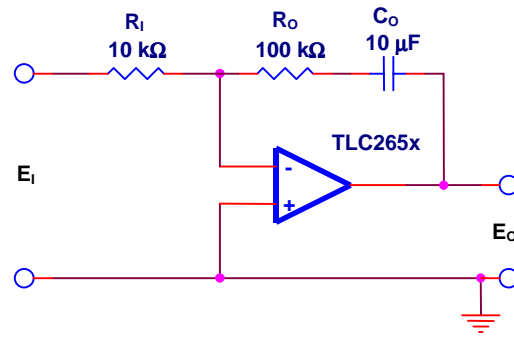

$$E_o = \frac{-R_o E_i}{R_1} - \frac{1}{C_o R_1} \int E_i dt$$
$$= -10 E_i - \int E_i dt$$

DIFFERENTIATORS

For the differentiator; $Z_o = R_o$, $Z_i = \frac{1}{C_p}$

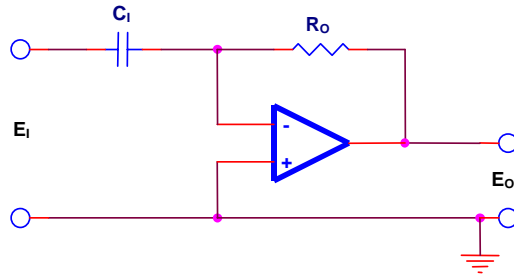

$$E_o = \frac{-Z_o}{Z_i} E_i = -R_o C_i \frac{dE_i}{dt}$$

The ideal differentiator circuit is not generally usable in its simple form. It is susceptible to high frequency noise that may be greater than the derivative output. Design should include high frequency response limiting.

With “Stop”

Input resistor sets high frequency cutoff.

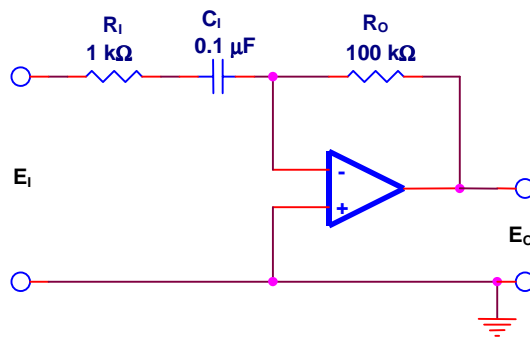

$$\text{High frequency cutoff: } F_o = \frac{1}{2\pi R_i C_i} = 0.6 \text{ kHz}$$

$$\text{Low frequency cutoff: } F_i = \frac{1}{2\pi R_o C_i} = 16 \text{ kHz}$$

Low Noise

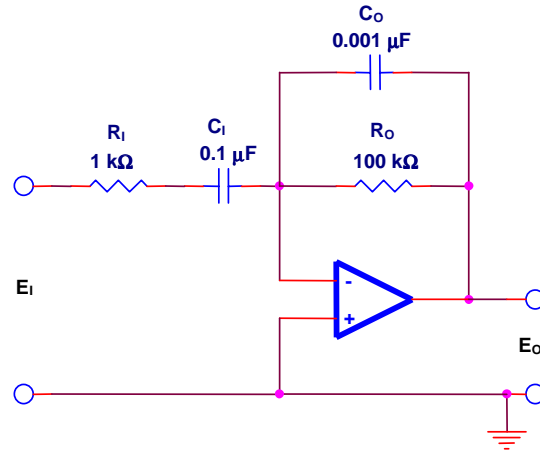

$$R_1 C_1 = R_o C_o \text{ drift compensating resistor}$$

Double high frequency cutoff.

Augmented Differentiator

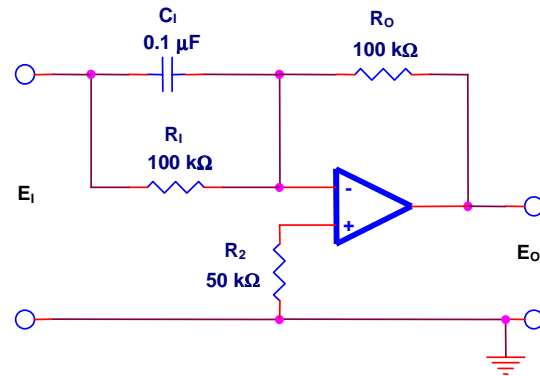

$$E_o = \frac{-R_o E_i}{R_1} - R_o C_1 \frac{dE_i}{dt}$$

$$E_o = -E_i - \frac{1}{100} \frac{dE_i}{dt}$$

Sums input and its derivative.

THE VOLTAGE SUMMER

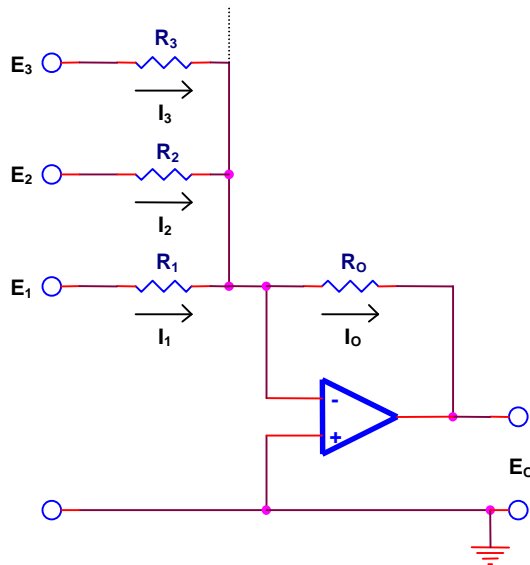

Assume the ideal summing point restraints:

1. Pin (1) is at ground potential
2. $-I_o + I_1 + I_2 + I_3 + \dots = 0$

The current, I_o , is given by:

$$I_o = \frac{-E_o}{R_o} = \frac{E_1}{R_1} + \frac{E_2}{R_2} + \frac{E_3}{R_3} + \dots$$

So that:

$$E_o = -R_o \left(\frac{E_1}{R_1} + \frac{E_2}{R_2} + \frac{E_3}{R_3} + \dots \right)$$

Thus, each input, E_n , is multiplied by a factor, $\frac{-R_o}{R_n}$, before summing.

SUMMING AND AVERAGING AMPLIFIERS

Voltages are summed by applying the signals to the same input of the amplifier. Amplifying, averaging, etc., may be accomplished by input resistor scaling. Inputs are effectively isolated from each other. Any number of inputs may be used in each of these circuits.

Adder

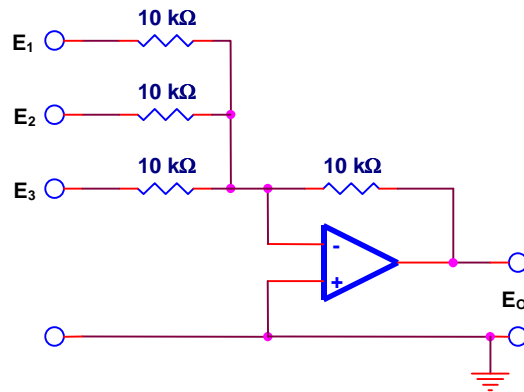

$$E_O = -(E_1 + E_2 + E_3)$$

$$Z_{in} = 10 \text{ k}\Omega \text{ for each input}$$

Output is inverted algebraic sum of inputs.

Scaling Adder

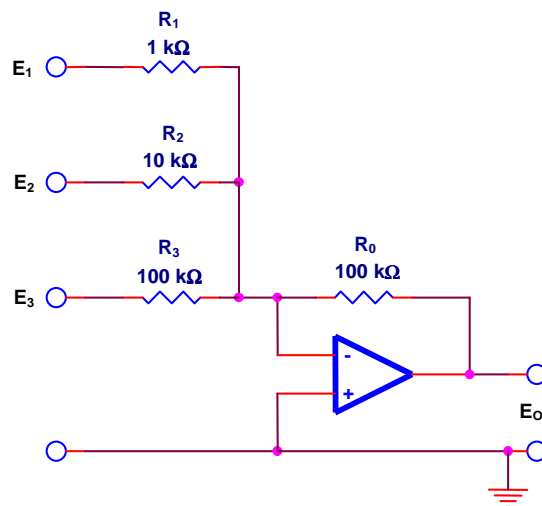

$$E_O = \left(\frac{R_0}{R_1} E_1 + \frac{R_0}{R_2} E_2 + \frac{R_0}{R_3} E_3 \right) = -100(100E_1 + 10E_2 + E_3)$$

$$Z_{in} = 1 \text{ k}\Omega \text{ for } E_1 = 10 \text{ k}\Omega \text{ for } E_2 = 100 \text{ k}\Omega \text{ for } E_3$$

Each input is multiplied by a constant before summing-inverting output.

Direct Addition

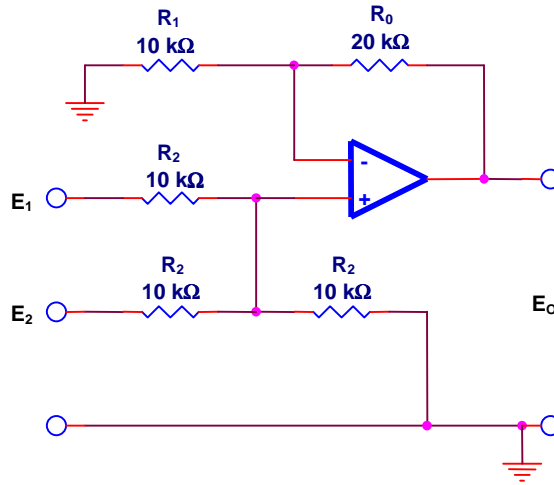

$$E_O = E_1 + E_2$$

$$Z_{in} = \frac{3}{2}R_2 = 15 \text{ k}\Omega \text{ for each input}$$

$$R_O = 2R_1$$

Non-inverting output.

Averager

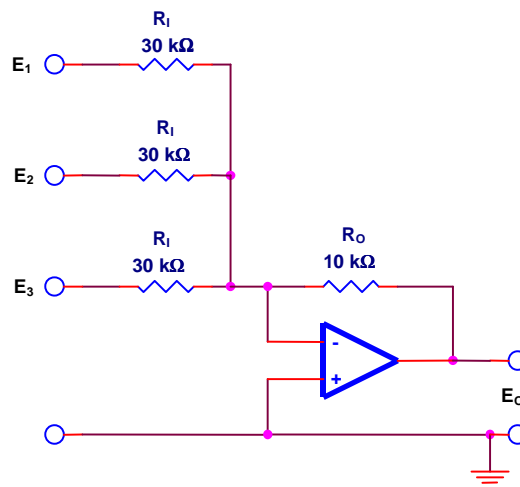

$$E_O = \frac{-R_O}{R_1} (E_1 + E_2 + E_3) = -\frac{E_1 + E_2 + E_3}{3}$$

$R_O = R_1$ divided by number of inputs

Output is inverted average of input signals. Ground unused inputs to preserve scale.

Weighted Average

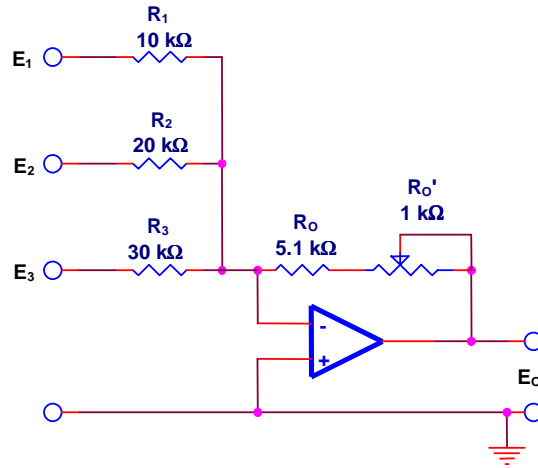

For $E_1 = E_2 = E_3$, set $R_{O'}$ so $E_O = E_1$

Then, $R_O + R_{O'} = R_1 \parallel R_2 \parallel R_3$

$$E_O = \frac{-(R_O + R_{O'})E_1}{R_1} - \frac{(R_O + R_{O'})E_2}{R_2} - \frac{(R_O + R_{O'})E_3}{R_3} = \frac{-(16.4E_1 + 8.2E_2 + 5.4E_3)}{30}$$

Each input is multiplied by a weighting factor before averaging.

THE DIFFERENTIAL INPUT AMPLIFIER

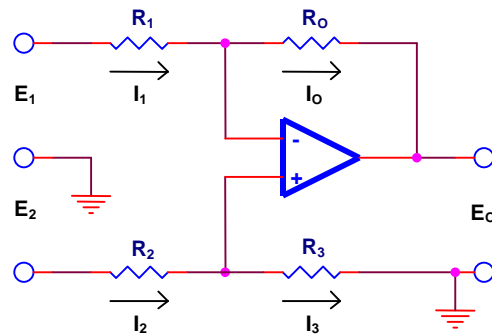

Assume the ideal input restraints:

1. The input pins reside at the common mode voltage, E_f .
2. $I_o = I_1$, $I_2 = I_3$

Current in the top leg is given by:

$$I_1 = \frac{E_1 - E_f}{R_1} = \frac{E_f - E_o}{R_o}$$

Solving for E_o :

$$E_o = E_f \left(1 + \frac{R_o}{R_1} \right) - \frac{R_o}{R_1} E_1$$

Due to current in the bottom leg, R_2 and R_3 act as a simple voltage divider:

$$E_f = \frac{R_3}{R_2 + R_3} E_2$$

Substituting:

$$E_o = \left(\frac{R_3}{R_2 + R_3} \right) \left(1 + \frac{R_o}{R_1} \right) E_2 - \frac{R_o}{R_1} E_1 = \frac{R_3}{R_1} \left(\frac{R_1 + R_o}{R_2 + R_3} \right) E_2 - \frac{R_o}{R_1} E_1$$

For $R_2 = R_1$ and $R_3 = R_o$, this reduces to:

$$E_o = \frac{R_o}{R_1} (E_2 - E_1)$$

(Ground reference point does not matter. Input may be “floating” if desired.)

Adder-Subtractor or Floating Input Combiner

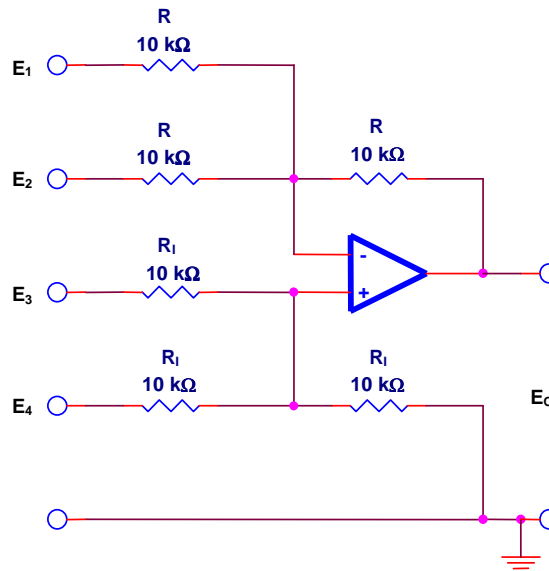

As an adder-subtractor, unused inputs should be grounded.

$$E_o = -E_1 - E_2 + E_3 + E_4$$

R and R_1 not necessarily equal

Two or more “floating” inputs maybe combined by connecting them across E_3 to E_1 and E_4 to E_2 .

THE DIFFERENTIAL (BALANCED) OUTPUT AMPLIFIER

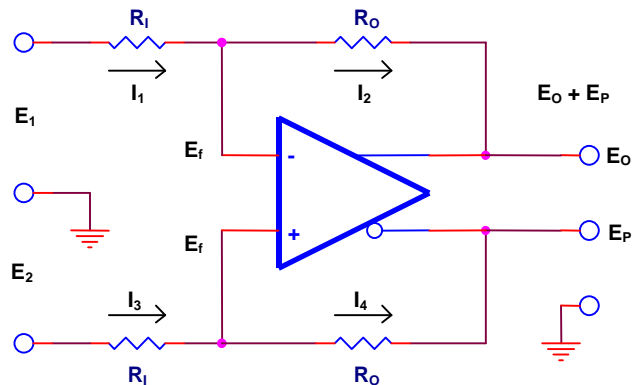

Assume the ideal input restraints:

1. The inverting and non-inverting inputs reside at the same common mode voltage, E_f
2. $I_1 = I_2$, $I_3 = I_4$

Current in the top leg is given by:

$$I_1 = \frac{E_1 - E_f}{R_i} = \frac{E_f - (E_O + E_P)}{R_o}$$

Current in the bottom leg is given by:

$$I_3 = \frac{E_2 - E_f}{R_i} = \frac{E_f - E_P}{R_o}$$

Subtracting these two equations:

$$\frac{E_1 - E_2}{R_i} = \frac{-E_O}{R_o}$$

Or:

$$E_O = \frac{R_o}{R_i} (E_2 - E_1)$$

(Ground reference is not critical. Input may be “floating” if desired.)

Note that the values of E_f and E_P are not uniquely determined by the above equations. In practice, this means that E_P will reside at same value determined by the internal circuitry of the operational amplifier itself plus the effects of drift. However, E_O will remain accurately fixed by the differential gain equation above.

DC AMPLIFIERS

There are two basic circuits, inverting and non-inverting, plus the differential output form.

Simple Inverting sign changing amplifier

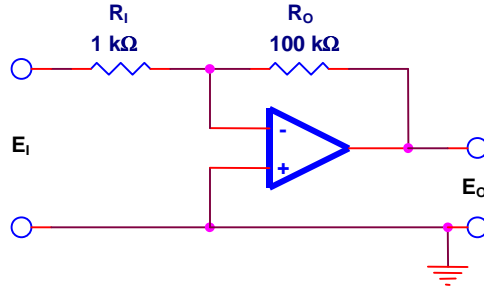

$$E_o = \frac{-R_o}{R_i} E_i = -100E_i$$

$$\text{resistor} = \frac{R_o R_i}{R_i + R_o} = 1 \text{ k}\Omega$$

$$Z_{in} = R_i = 1 \text{ k}\Omega$$

Chopper Stabilized

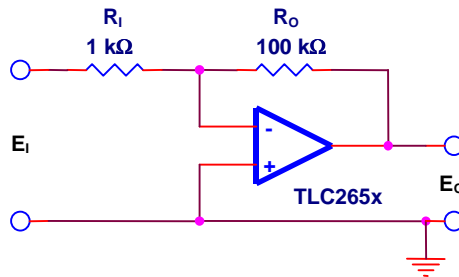

Improved drift and stability.

Simple Gain Control

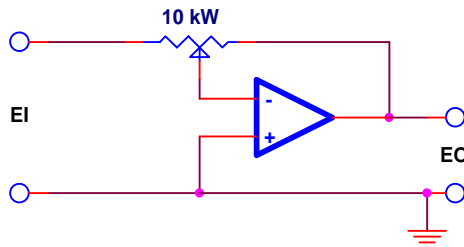

Wide range gain or attenuation.

Unity gain with R centered. The gain is not linear with potentiometer setting. Z_{in} drops as gain is increased.

Linear Gain Control

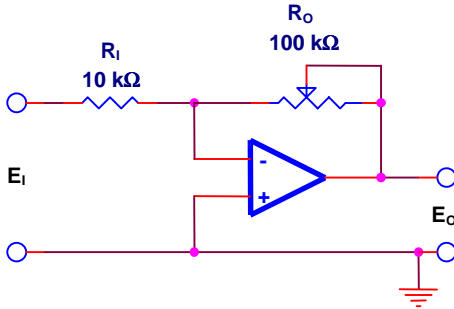

Variable from 0 to 10

$$E_o = 0 \text{ to } -10E_i$$

$$Z_{in} = R_i = 10 \text{ k}\Omega$$

Simple Non-Inverting

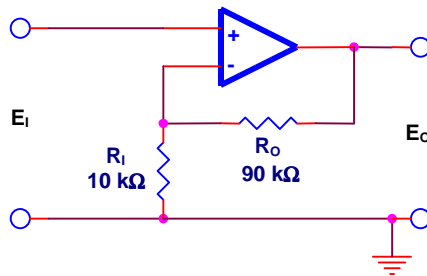

Input common mode voltage limit must be observed.

$$E_o = \frac{R_o + R_i}{R_i} E_i = 10E_i$$

Gain controls and/or trimming may be accomplished as in the variations on the inverting amplifier above.

Power Booster

Output current of any of the above circuits may be increased by the addition of a power booster. The operational amplifier - booster combination is substituted directly for the original operational amplifier.

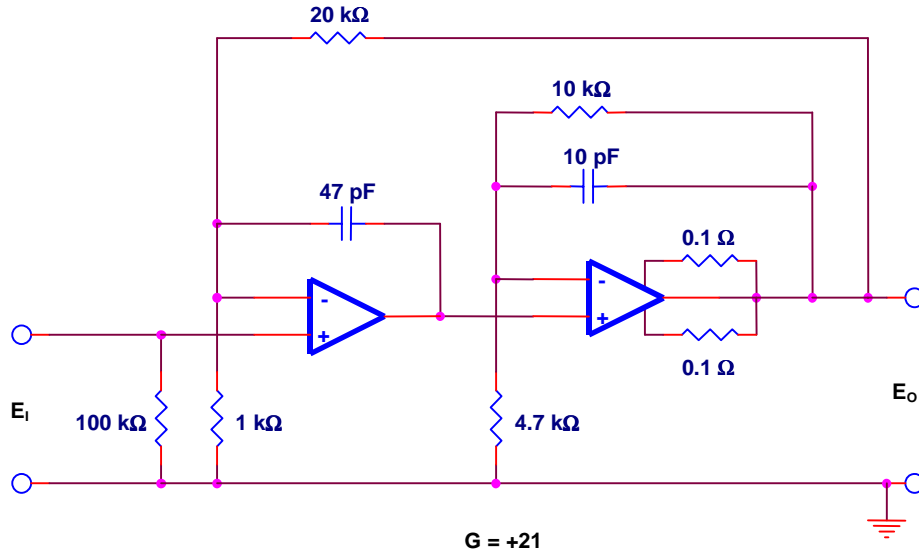
Table 1. Compound Amplifier, Resulting Performance

Parameter	OPA277	OPA512	Compound
V_{OS}	20 μ V	6 mV	20 μ V
Drift	0.15 μ V/ $^{\circ}$ C	65 μ V/ $^{\circ}$ C	0.15 μ V/ $^{\circ}$ C
I_B	1 nA	30 nA	1 nA
CMRR	130 dB	100 dB	130 dB
V_{OUT}	\pm 13 V	\pm 35 V	\pm 35 V
I_{OUT}	5 mA	10 A	10 A
SR	0.8 V/ μ S	2.5 V/ μ S	2.4 V/ μ S

This circuit addresses the need for a power output stage with a precision input circuit. The combination is not available in one device. It is possible to combine the power capabilities of the OPA512 with the precision of the OPA277. The OPA512 has the highest slew rate and therefore is operated within a local closed loop. The slower OPA277 is operated within the outer loop. The 47pF capacitor provides a small amount of phase shift to help stabilize the system. The resulting performance of the compound amplifier shows that the front-end characteristics of the OPA277 are joined with the \pm 35V at 10A drive current capabilities out of the OPA512. The slew rate of the OPA277 is 0.8V/ μ s. That slew rate is gained up times three in the OPA512 so that there is an effective slew rate for the compound amplifier of 2.4V/ μ s.

Differential Output

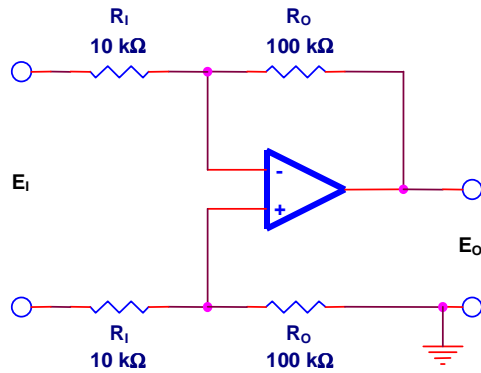

$$E_o = \frac{R_o}{R_i} E_i = 10E_i$$

For driving floating load.

Gain Control

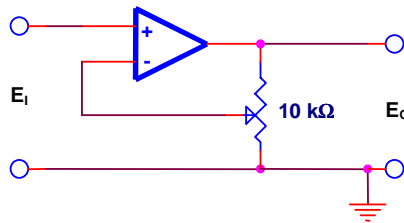

Equivalent to replacing both resistors in the non-inverting amplifier. Observe common mode voltage limit.

Inverting Gain Control

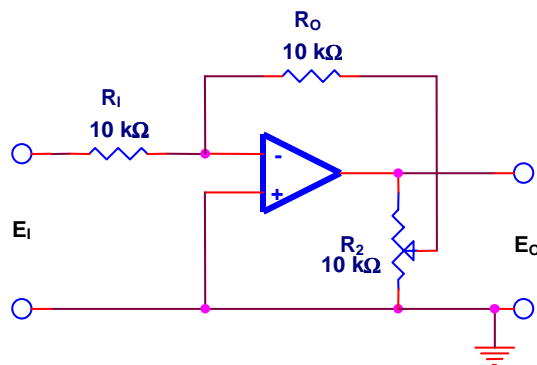

$$E_o = (-1 \text{ to infinity}) E_i$$

$$Z_{in} = 10 \text{ k}\Omega$$

Convenient gain technique

DIFFERENTIAL AMPLIFIERS

In differential amplifiers, separate input signals are applied to the differential inputs of the operational amplifier. The result is direct subtraction in contrast to the summing amplifier that adds algebraically.

Subtractor

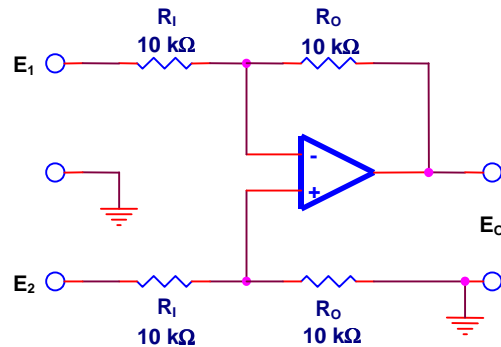

$$E_o = E_2 - E_1$$

Direct subtraction of two inputs.

Difference Amplifier

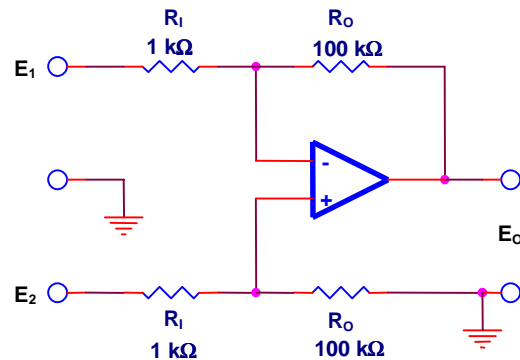

$$E_o = \frac{-R_o}{R_1}(E_1 - E_2) = 100(E_2 - E_1)$$

Subtractor with amplification.

Common Mode Rejection

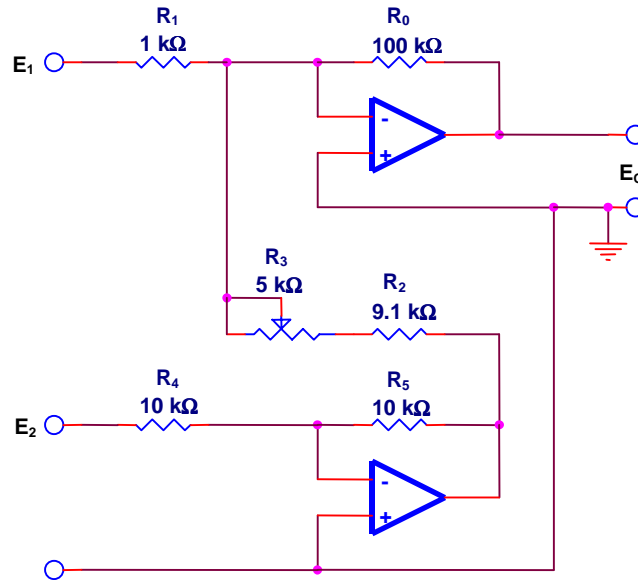

$$E_o = \frac{-R_o}{R_1}(E_1 - E_2) = 10(E_2 - E_1)$$

$$R_2 + R_3 = R_1$$

Subtraction by inverting and summing to eliminate common mode voltage.

R_3 - common mode adjustment. Set for Zero output when $E_1 = E_2$.

Differential Input-Output

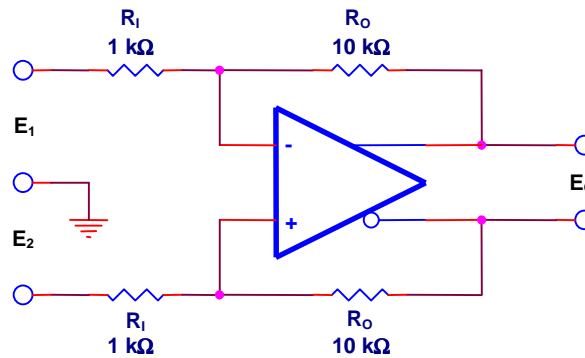

For use in driving floating loads. Input may be floating source.

AC AMPLIFIERS

DC Amplifiers with Blocking Capacitors

AC operational amplifier circuits will amplify low frequency signals that are below the range of more conventional amplifiers (0.1 Hz to 20 kHz) while DC blocking still is present. Only a single ended supply is required in one circuit. DC and AC operational amplifier circuits are equivalent at higher frequencies.

Simple Amplifier

Simple RC roll off at low frequency.

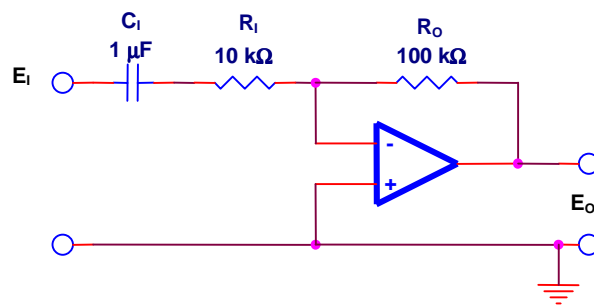

$$E_o = -\frac{R_o}{R_1} E_i = -10E_i$$

$$Z_{in} = 10 \text{ k}\Omega$$

$$\text{Low frequency rolloff begins: } f_{-3\text{dB}} = \frac{1}{2\pi R_1 C_1} = 16 \text{ Hz}$$

Single Supply

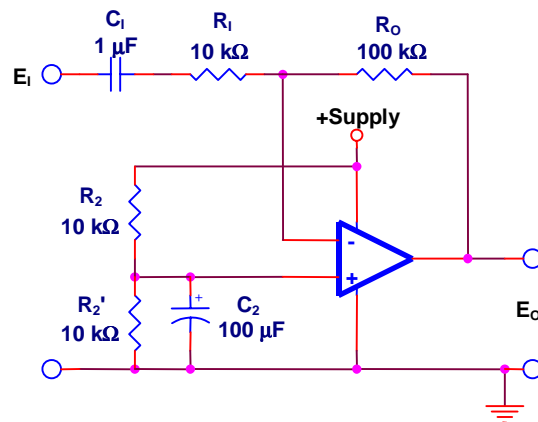

Equivalent to above, with the supply “floated” above ground.

Non-Inverting

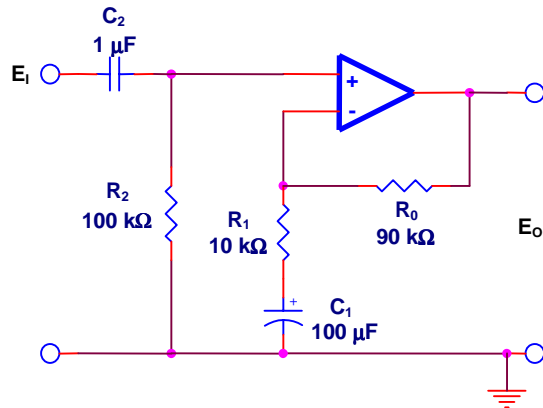

E_o in phase with E_i

$$E_o = \frac{R_o + R_1}{R_1} = 10E_i$$

$$\text{Low frequency rolloff } f_{-3\text{dB}} = \frac{1}{2\pi R_1 C_1} = 0.16 \text{ Hz}$$

Double Roll-off

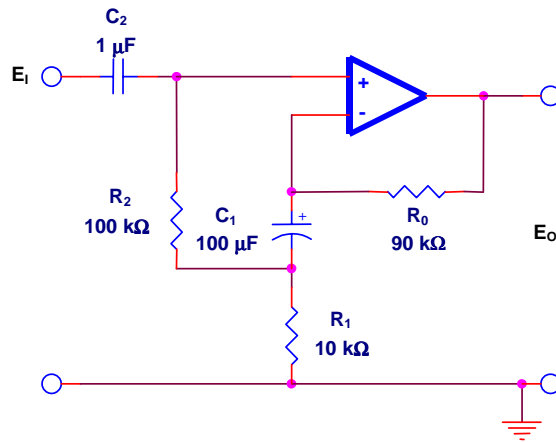

Similar to above.

$$C_1 R_1 = C_2 R_2$$

AC Preamplifier

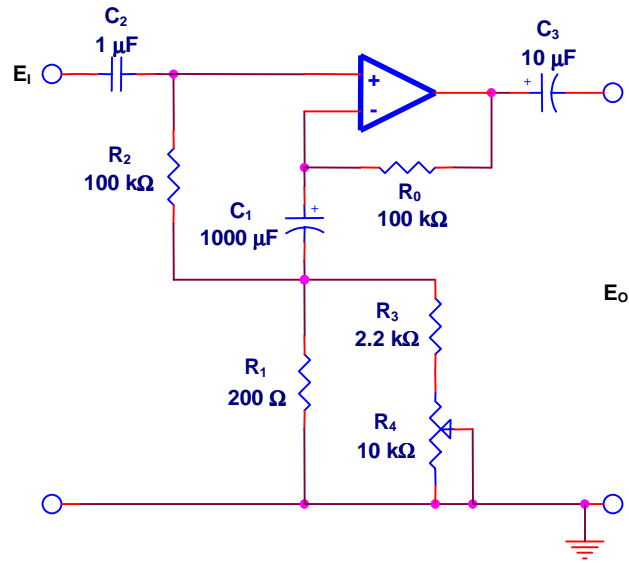

Completely developed AC amplifier with high Z_{in} and double rolloff rate and gain trim.

$$\frac{E_o}{E_i} = \frac{R_0 + R_1}{R_1} = 500$$

R_4 - Fine gain adjust

$$\text{Low Frequency rolloff begins } f_{-3\text{dB}} = \frac{1}{2\pi R_1 C_1} = 1.6 \text{ Hz}$$

$$R_1 C_1 = R_2 C_2$$

CURRENT OUTPUT DEVICES

These amplifiers will supply output current to a load in linear correspondence to the input voltage.

Feedback Loop

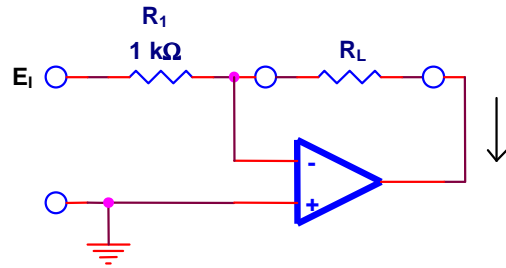

$$I = \frac{E_i}{R_1} = E_i \text{ mA}$$

$$Z_{in} = R_1 = 1 \text{ k}\Omega$$

Simple Meter Amplifier

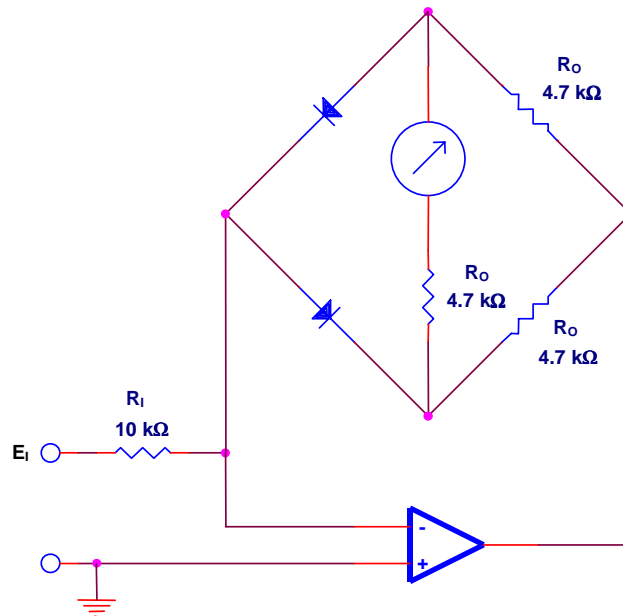

$$I_{\text{meter}} = \frac{E_i}{3R_1} = \frac{E_i}{30} \text{ mA}$$

Linear current meter reads AC input voltage.

Meter Amplifier

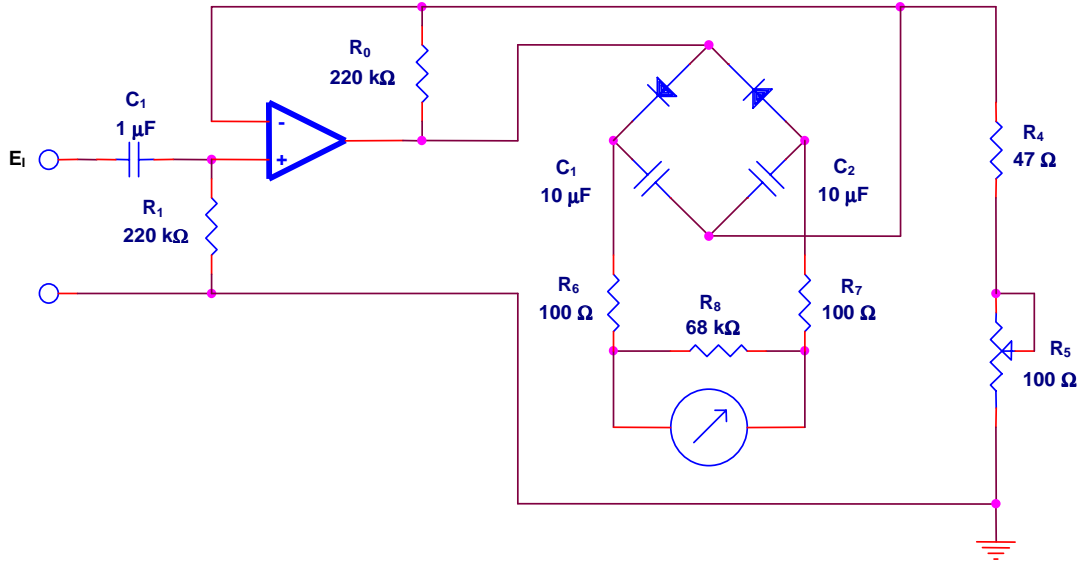

$$\text{Meter reading} = \frac{0.9E_1}{R_4 + R_5} \text{ (rms)}$$

R₅: gain control (calibration)

Fully developed average reading meter

Current Injector

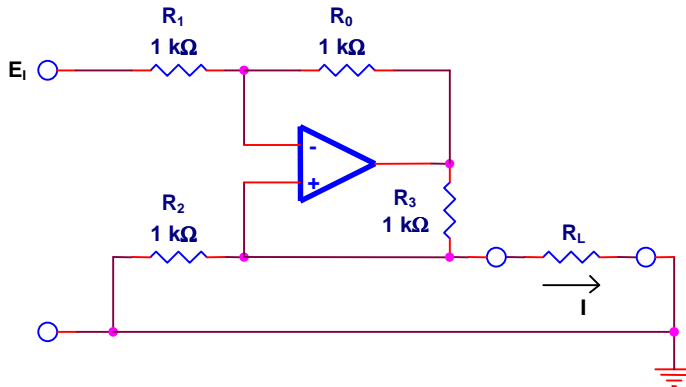

$$I = -\frac{E_1}{R_L} = -E_1 \text{ mA}$$

$$\frac{R_1}{R_2} = \frac{R_0}{R_3}$$

Single terminal current available to ground. Observe common mode voltage limit.

Linear Current Source

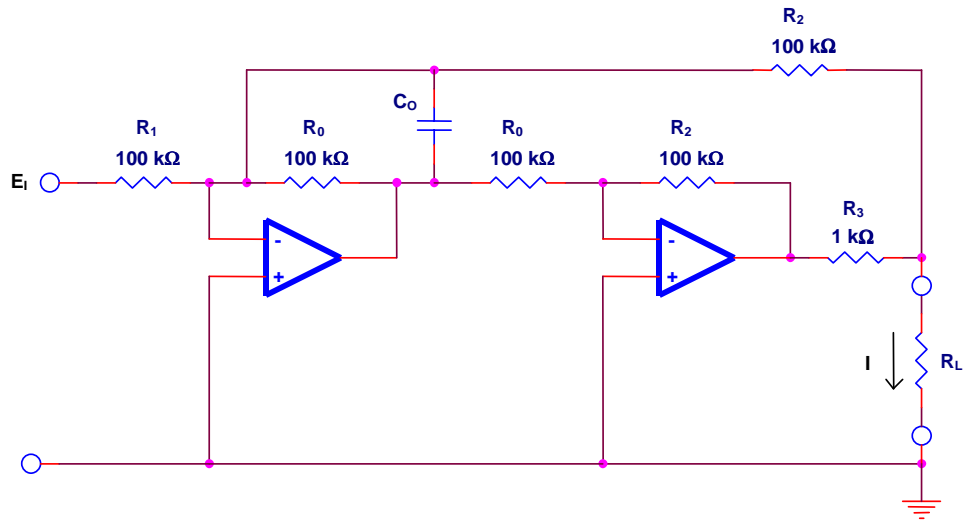

When $R_L \ll R_2$,

$$\frac{I_L}{E_1} = \frac{R_2}{R_1 R_3} = \frac{1 \text{ mA}}{\text{Volt}}$$

C_0 added for high frequency stability.

Change R_3 for current scaling:

Table 2. Current Source Scaling Resistors

R_3	I_L/E_1
1 kΩ	1 mA / Volt
100 Ω	10 mA / Volt
10 Ω	100 mA / Volt

Deflection Coil Driver

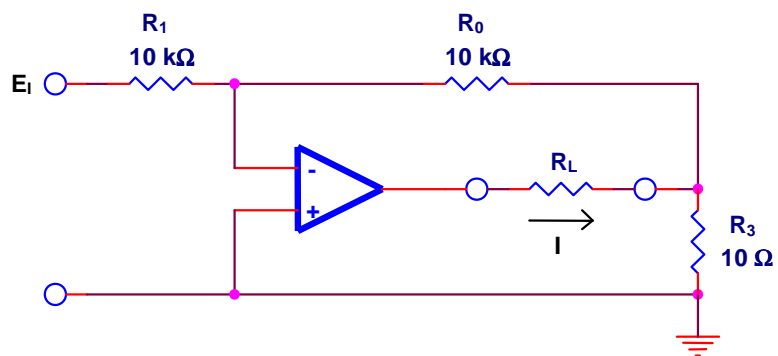

$$\frac{I}{E_1} = \frac{-R_0}{R_1 R_3} = -100 \text{ mA / Volt}$$

Load must be "floating," i.e. ungrounded.

OSCILLATORS AND MULTI VIBRATORS

Oscillators give a continuous sine wave, output. Multivibrator output fixed voltage level or square wave similar to flip-flop output.

Simple Oscillator

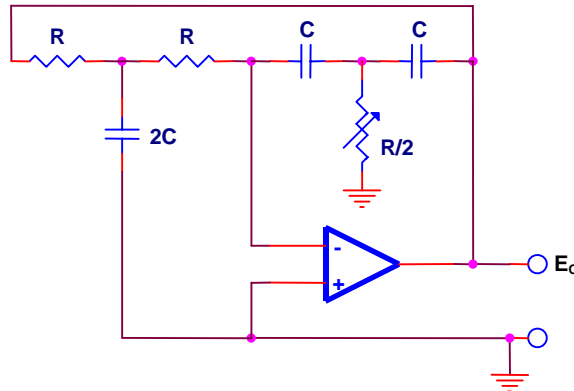

$$f = \frac{1}{2\pi RC}$$

Double integrator circuit with regenerative feedback. Components R, C, and 2C should be very low tolerance. Trim R/2 until oscillation is barely sustained.

Wien Bridge Oscillator

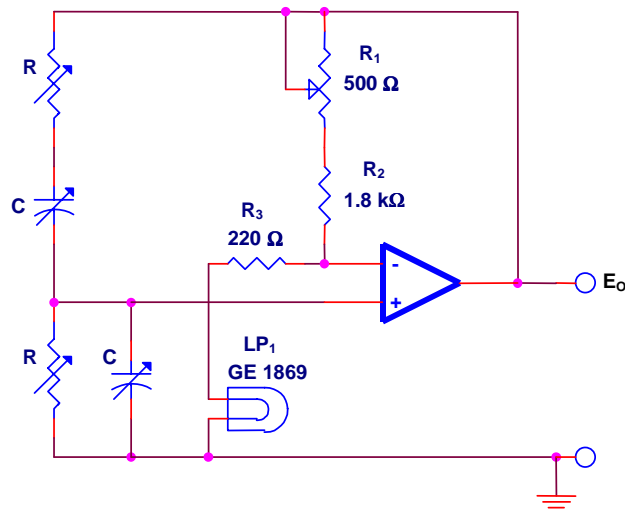

$$f_o = \frac{1}{2\pi RC}, 100 \text{ to } 6000 \text{ Hz}$$

High purity sine wave generation.

PHASE LEAD AND LAG NETWORKS

These networks are used to stabilize servo systems by introducing phase shift as desired. Transient and steady state responses may be tailored semi-independently.

Lag Element

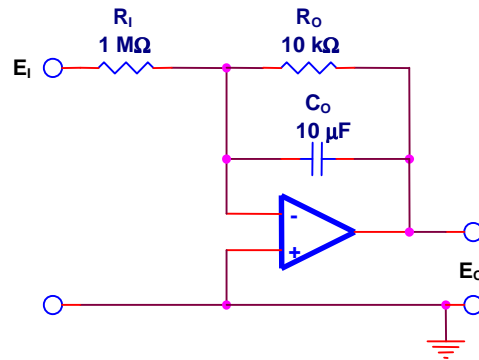

$$E_o = \frac{-R_o}{R_i} \frac{E_i}{1 + R_o C_o P} = \frac{-10E_i}{10 + P}$$

Integrating type phase lag.

Adjustable Lag

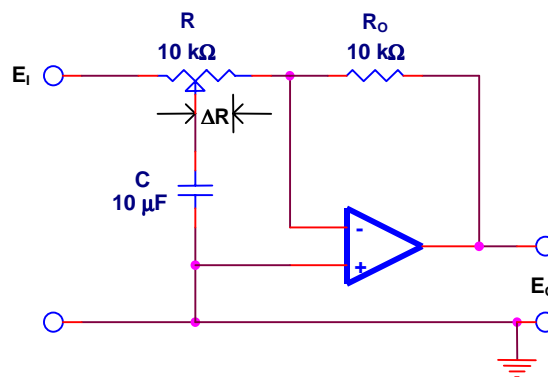

Non-integrating type. Constant inverting unity gain. Maximum lag for R centered for $\Delta = \frac{1}{2}$ where $0 \leq \Delta \leq 1$ is the log setting.

$$E_o = \frac{-E_i}{1 + (\Delta - \Delta^2) R C P} = \frac{-40E_i}{40 + P}$$

Lag value linear with R setting

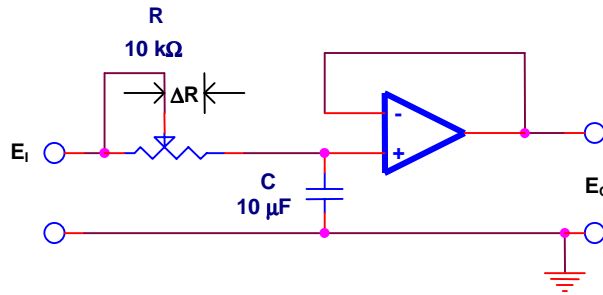

$$E_o = \frac{E_i}{1 + \Delta R C P} = \frac{10 E_i}{10 + P}$$

$P = \text{operator, } \frac{d}{dt} \text{ or } j\omega$

Non-inverting low distortion

Adjustable Lead

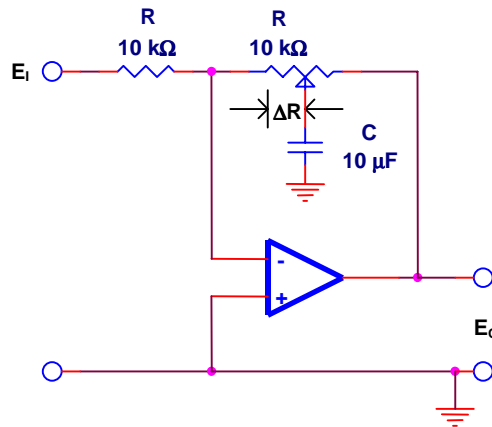

$$E_o = -(\Delta - \Delta^2) R C P E_i$$

Putting input network from adjustable lag circuit in feedback path gives lead element.

Lead-Lag

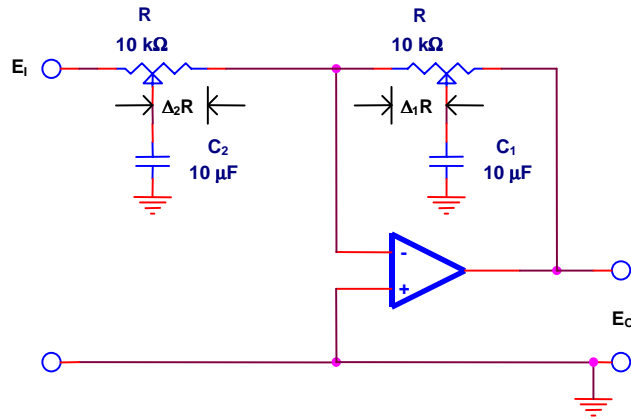

$$E_o = \frac{1 + (\Delta_1 - \Delta_1^2) RC_1 P}{1 + (\Delta_2 - \Delta_2^2) RC_2 P} E_i$$

Composite lead and lag network.

Time Delay

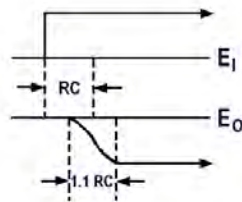
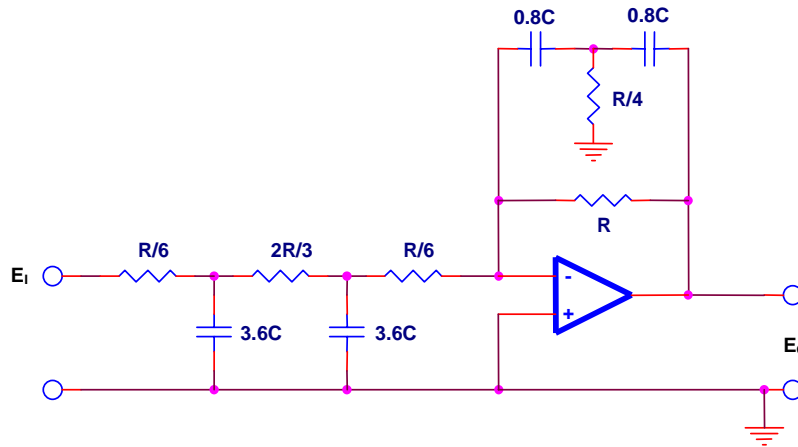

Unity gain phase or time shift.

ADDITIONAL CIRCUITS

The following are various circuits that do not fall into one of the categories of the previous sections.

Absolute Value

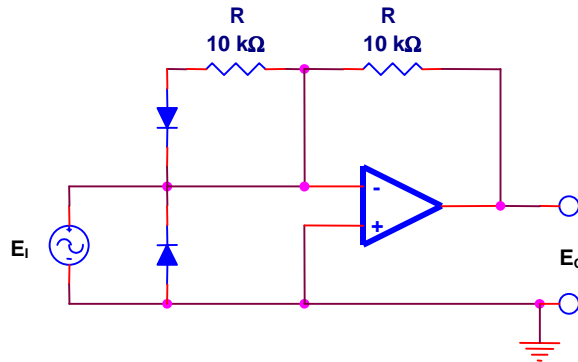

+ E_i follower circuit

- E_i inverter circuit

$$E_o = |E_i|$$

Full wave rectification. Reverse diodes to give $E_o = -|E_i|$

Peak Follower

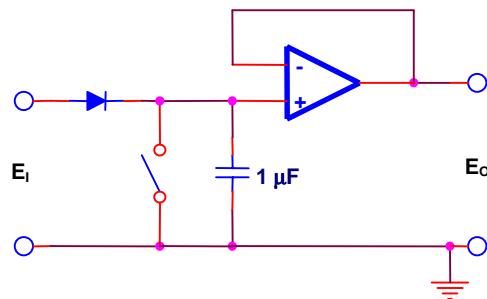

Peak value memory. Use low leakage capacitor. $E_o = E_i$ maximum. Common mode input voltage must be observed.

Precision Rectifier

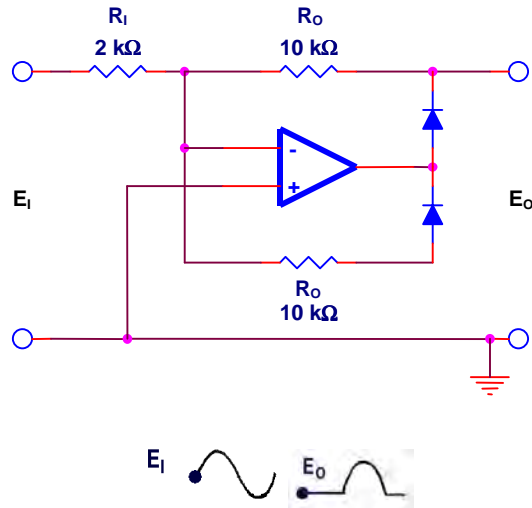

$$E_o \text{ peak} = \frac{-R_o}{R_i} E_i \text{ peak} = -5E_i \text{ peak}$$

Half wave with amplification if desired. Placing rectifiers in feedback loop decreases non-linearity to very small value.

AC to DC Converter

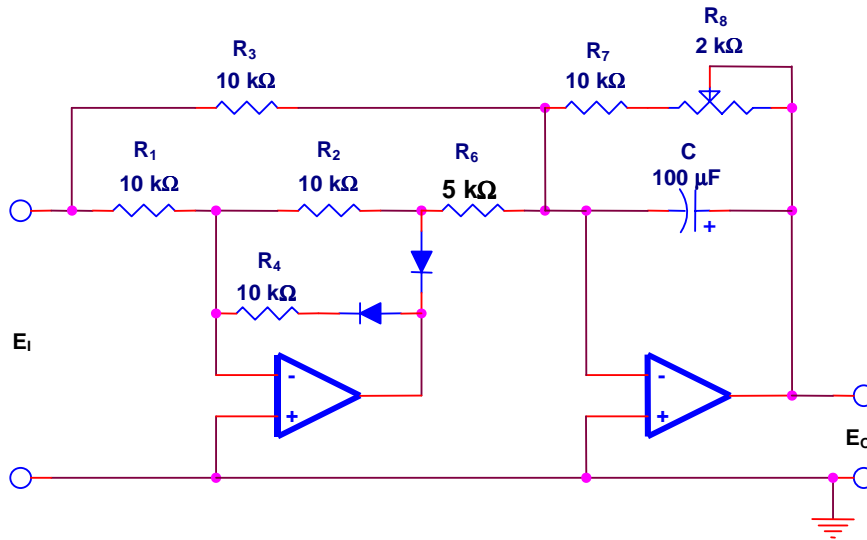

$$E_o \text{ average} = 0.9E_i \text{ rms}$$

$$E_i = 6 \text{ mV to } 6 \text{ V rms @ } 10 \text{ to } 1000 \text{ Hz}$$

Precision conversion for measurement or control. Full wave rectifier with a smoothing filter.

Full Wave Rectifier

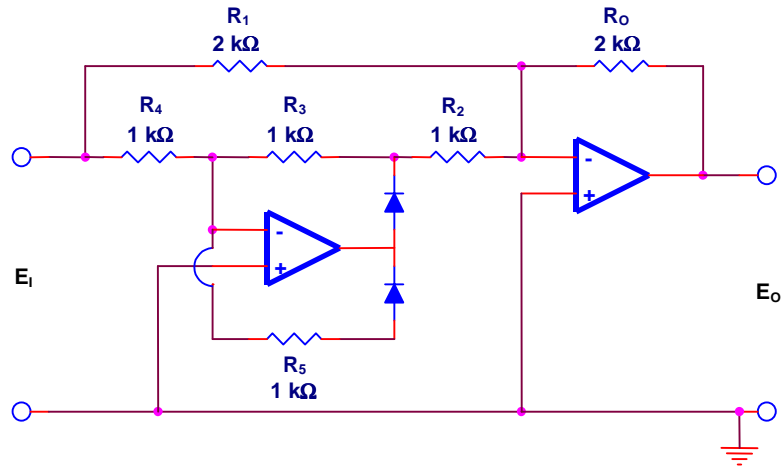

Precision absolute value circuit.

Rate Limiter

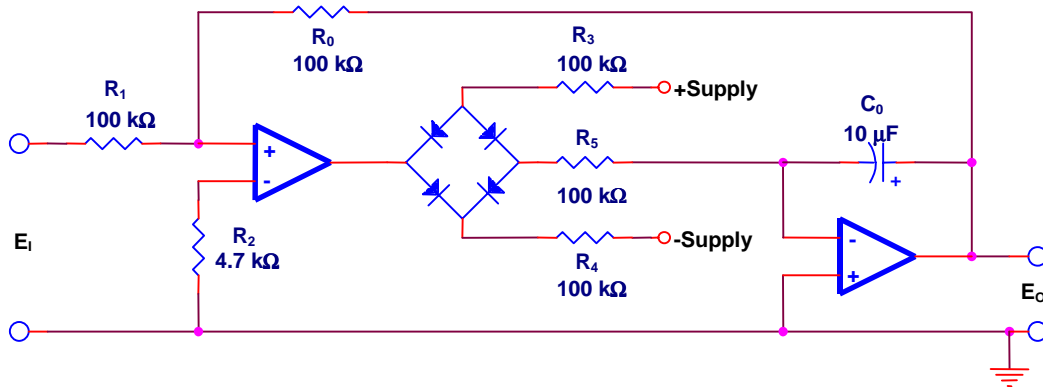

$$E_o = \frac{-R_o}{R_1} E_i = -E_i$$

Rate limit = 7.5 V/sec

Time Delay

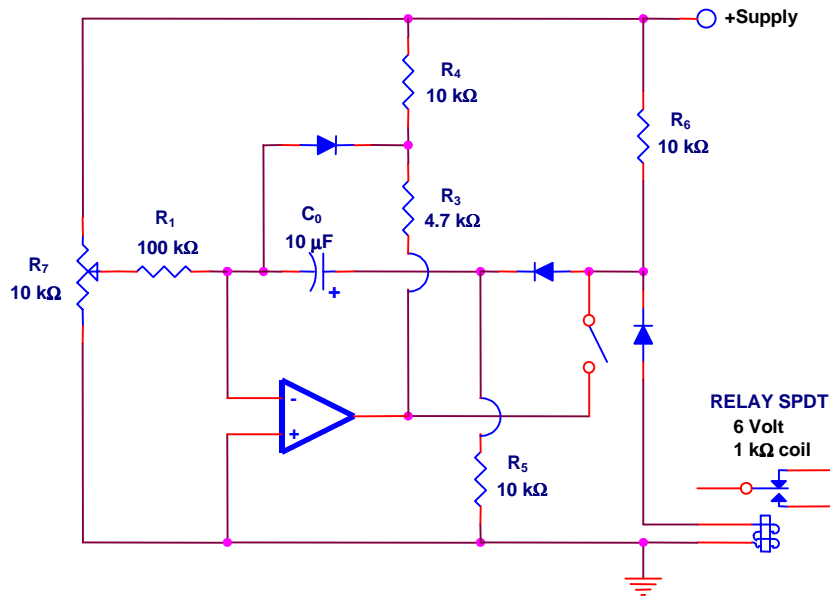

$$\text{Delay} = \frac{R_1 C_0}{2K_1}$$

Where K is setting of R_1 , 0, $K < 1$

Time operated relay. Open switch to reset, close to being timing.

Selective Amplifier

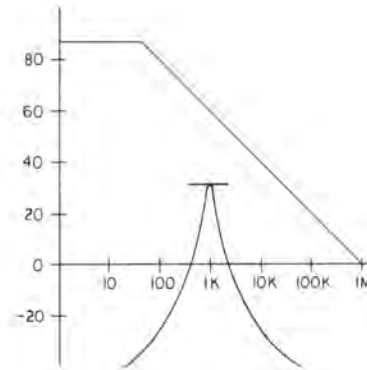
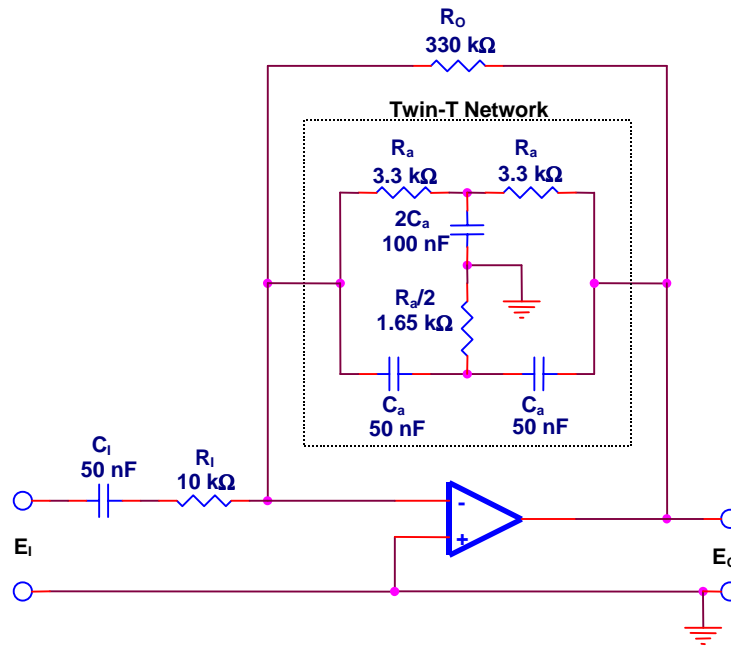

Twin T feedback

$$\text{Frequency peak} = \frac{1}{2\pi R_a C_a} = 1000 \text{ Hz}$$

$$\text{Gain at peak} = \frac{R_o}{R_i} = 33 = 30 \text{ dB}$$

Set C_i so that $C_i R_i > 2C_a R_a$ and $R_i < 100 \text{ k}\Omega$

$$Z_{in} = R_i = 10 \text{ k}\Omega$$

$$Z_{out} < 200 \Omega$$

SECTION III: SELECTING THE PROPER OPERATIONAL AMPLIFIER

Now, with the theory, circuits, and test procedures at our command, we are ready to select an amplifier. A glance at the representative specifications, given in the Appendix, shows the variety of ratings available. These represent only a small fraction of the operational amplifiers available from Burr-Brown alone. This section presents several approaches to selecting the proper operational amplifier from the wide range of available units.

Focus on Limiting Specifications

To apply the operational amplifier correctly, none of its ratings should be exceeded. It would, however, be uneconomical to apply the device too conservatively. With so many specifications and so many amplifiers, the secret is to focus on the limiting specification.

In the majority of DC applications, the limiting factor will be DC drift. Drift in operational amplifiers is primarily due to temperature effects on the input transistors causing base voltages and base currents to vary. The input current offset (base current) must flow to ground through the external feedback network and through the source. The input current drift times the effective resistance to ground gives a voltage affect which may add to or subtract from the input voltage drift. If the resistance to ground is the same for both inputs, the input current variations tend to cancel as indicated by the specification, "differential current drift." A comparison of the input stability (combined effects of voltage and current drifts over your temperature range) with your input signal will give a quick indication of the accuracy you can expect.

Specifications other than drift that can help you focus on the proper amplifier are bandwidth, output capability, and packaging. The requirement for a high gain-bandwidth product may narrow the field to a few high-speed amplifiers. High power output requirements may rule out the smaller packages and more economical units. A packaging preference will rule out comparable units in other configurations.

While any one of seventy or more specifications could be limiting in your application, familiarity with operational amplifiers will enable you to spot quickly the critical parameter in your case.

Avoid Closed Loop vs. Open Loop Confusion

While an amplifier is never used open loop, in practical applications, open loop specifications are required to provide the information needed for all possible closed loop applications. As we have seen in the preceding sections, there may be a vast, but predictable, difference between open loop and closed loop characteristics such as input impedance, output impedance, and bandwidth. The amplifier for your application may be completely described with either closed loop specifications or open loop specifications, but the relationship between the two should be clearly understood.

Selection Check List

The following is a checklist of the information required to select the proper amplifier for your needs. Be sure you have enough information.

1. The Source: What type of source do you have? Voltage level? Impedance?

2. The Load: What type of load do you have? Voltage level required? Impedance?
3. Performance: In the closed loop, what is the required gain? Bandwidth? Accuracy? Linearity? Input Impedance? Output Impedance? DC drift? Noise? In the open loop, what standard Texas Instruments amplifier will do this? Any exceptions? Formal specifications? Available in system/instrument?
4. Environment: Where will the amplifier be used? Temperature range? Other requirements?
5. Power Supply: Number of amplifiers per supply? Current drain?
6. Package: Type of mounting? Controls? Connectors?
7. Availability: Quantity? Future potential? Delivery requirements? Price?

The above information will define your requirement fully.

Assistance Available from Texas Instruments

The following services are available to you for the asking.

- The latest specifications and devices - Operational amplifiers are continually being improved and new models introduced. Be sure your information is up to date.
- Applications assistance - given the information in the preceding checklist, an amplifier will be recommended with an appropriate circuit.
- Availability - Get all the information you need for on-schedule installation at minimum cost.

Contact Texas Instruments or your nearest representative for any or all of these services.

References

1. Texas Instruments, [Op Amps and Comparators - Don't Confuse Them](#), SLOA067, Bruce Carter, 09/06/2001
2. Texas Instruments, [How \(Not\) To Decouple High-Speed Operational Amplifiers](#), SLOA069, Bruce Carter, 09/12/2001
3. Texas Instruments, [Differential Op Amp Single-Supply Design Techniques](#), SLOA072, Bruce Carter, 09/17/2001

IMPORTANT NOTICE

Texas Instruments Incorporated and its subsidiaries (TI) reserve the right to make corrections, modifications, enhancements, improvements, and other changes to its products and services at any time and to discontinue any product or service without notice. Customers should obtain the latest relevant information before placing orders and should verify that such information is current and complete. All products are sold subject to TI's terms and conditions of sale supplied at the time of order acknowledgment.

TI warrants performance of its hardware products to the specifications applicable at the time of sale in accordance with TI's standard warranty. Testing and other quality control techniques are used to the extent TI deems necessary to support this warranty. Except where mandated by government requirements, testing of all parameters of each product is not necessarily performed.

TI assumes no liability for applications assistance or customer product design. Customers are responsible for their products and applications using TI components. To minimize the risks associated with customer products and applications, customers should provide adequate design and operating safeguards.

TI does not warrant or represent that any license, either express or implied, is granted under any TI patent right, copyright, mask work right, or other TI intellectual property right relating to any combination, machine, or process in which TI products or services are used. Information published by TI regarding third-party products or services does not constitute a license from TI to use such products or services or a warranty or endorsement thereof. Use of such information may require a license from a third party under the patents or other intellectual property of the third party, or a license from TI under the patents or other intellectual property of TI.

Reproduction of information in TI data books or data sheets is permissible only if reproduction is without alteration and is accompanied by all associated warranties, conditions, limitations, and notices. Reproduction of this information with alteration is an unfair and deceptive business practice. TI is not responsible or liable for such altered documentation.

Resale of TI products or services with statements different from or beyond the parameters stated by TI for that product or service voids all express and any implied warranties for the associated TI product or service and is an unfair and deceptive business practice. TI is not responsible or liable for any such statements.

Mailing Address:

Texas Instruments
Post Office Box 655303
Dallas, Texas 75265