



SensComp, Inc.  
36704 Commerce Rd.  
Livonia, MI 48150  
Telephone: (734) 953-4783  
Fax: (734) 953-4518  
www.senscomp.com

## 6500 Series Ranging Modules

SensComp's Ranging Modules provide the drive electronics for SensComp Electrostatic Transducers

### Features

- Accurate Sonar Ranging from 6 inches to 35 feet
- Drives a 50 kHz Electrostatic Transducer Without an Additional Interface
- Operates from a Single Power Supply Source
- Accurate Clock Output Provided for External Use
- Selective Echo Exclusion
- TTL Compatible
- Multiple Measurement Capability
- Integrated Transducer Cable
- Variable Gain Control Potentiometer

### Part No.

- PID# 615078 -- 6500 Series Sonar Ranging Module
- PID# 615079 -- 6500 Series Enhanced Sonar Ranging Module; Includes Pull-up Resistors and an Internal Oscillator for Repetitive Operation
- PID# 615080 -- 6500 Series Sonar Ranging Module Without the Connector

### Description

The 6500 Series is an economical sonar ranging module that can drive all SensComp electrostatic transducers. This module, with a simple interface, is able to measure distances from 6 inches to 35 feet. The typical accuracy is +/- 1% of the reading over the entire range.

This module has an external blanking input that allows selective echo exclusion for operation on a multiple-echo mode. The module is able to differentiate echos from objects that are only three inches apart. The digitally controlled gain, variable bandwidth amplifier minimizes noise and side-lobe detection in sonar applications.

The module has an accurate ceramic resonator controlled 420 kHz time base generator. An output based on the 420 kHz time base is provided for external use. The sonar transmit output is 16 cycles at a frequency of 49.4 kHz.

The 6500 Series module operates over a DC power supply range from 4.5 volts to 6.8 volts (5 volts nominal) and is characterized for operation from 0° C to 40° C.

### Specifications

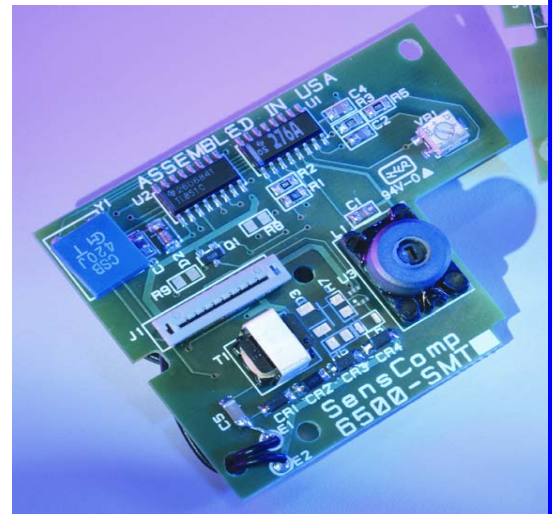

For more information, visit our website: [www.senscomp.com](http://www.senscomp.com)

7/24/03

**Absolute Maximum Ratings over Operating Free-air temperature range**

Voltage from any pin to ground (see Note 1) .....	7 VDC
Voltage from any pin except XDCR to $V_{CC}$ (see Note 1) .....	-7 VDC to 0.5 VDC
Operating free-air temperature range.....	0° C to 40° C
Storage temperature range .....	-40° C to 85° C

NOTE 1: The XDCR pin may be driven from -1 volt to 400 volts typical with respect to ground.

**Recommended Operating Conditions**

	MIN	MAX	UNIT
Supply Voltage, $V_{CC}$	4.5	6.8	V
High-level Input Voltage, $V_{IH}$	2.1		V
Low-level Input Voltage, $V_{IL}$		0.6	V
ECHO and OSC Output Voltage		6.8	V
Delay Time, Power Up to INIT High	5		ms
Recycle Period	80		ms
Operating Free-air Temperature, $T_A$	0	40	°C

**Electrical Characteristics over Recommended Ranges of Supply Voltage and Operating Free-Air Temperature**

PARAMETER		TEST COND.	MIN	TYP	MAX	UNIT
Input Current	BLNK, BINH, INIT	$V_I = 2.1$ V			1	mA
High-level Output Current, $I_{OH}$	ECHO, OSC	$V_{OH} = 5.5$ V			100	$\mu$ A
Low-level Output Voltage, $V_{OL}$	ECHO, OSC	$I_{OL} = 1.6$ mA			0.4	V
Transducer Bias Voltage		$T_A = 25^\circ$ C		200		V
Transducer Output Voltage (peak to peak)		$T_A = 25^\circ$ C		400		V
No. of Cycles for XDCR Output to Reach 400V		$C = 500$ pF			7	
Internal Blanking Interval				2.38†		ms
XMIT Drive Signal Duration				1.1†		ms
Frequency During 16-pulse	OSC output			49.4†		kHz
Transmit Period	XMIT output			49.4†		kHz
Frequency After 16-pulse	OSC output			93.3†		kHz
Transmit Period	XMIT output			0		kHz
Supply Current, $I_{CC}$	During transmit period				2000	mA
	After transmit period				100	mA

† These typical values apply for a 420 kHz ceramic resonator

**Operation With SensComp Electrostatic Transducers**

There are two basic modes of operation for the 6500 Series Sonar Ranging Modules: Single-echo mode and multiple-echo mode. The application of power ( $V_{CC}$ ), the application of the initiate (INIT) input, and the resulting transmit output, and the use of the Blanking Inhibit (BINH) input are basically the same for either mode of operation. After applying power ( $V_{CC}$ ) a minimum of 5 milliseconds must elapse before the INIT signal can be taken high. During this time, all internal circuitry is reset and the internal oscillator stabilizes. When INIT is raised to a high level, drive to the transducer (XDCR) output occurs. Sixteen pulses at 49.4 kHz with an amplitude of 0 volts to 400 volts peak to peak will excite the transducer as transmission occurs. At the end of the 16 transmitted pulses, a 200 VDC bias remains on the transducer (as recommended) for optimum receiving operation.

In order to eliminate ringing of the transducer from being detected as a return signal, the Receive (REC) input of the ranging control IC is inhibited by internal blanking for 2.38 milliseconds after the initiate signal. If a reduced blanking time is desired, then the BINH input can be taken high to end the blanking of the Receive input any time prior to internal blanking. This may be desirable to detect objects closer than 1.33 feet (corresponding to 2.38 milliseconds) and may be done if transducer damping is sufficient so that ringing is not detected as a return signal.

In the single-echo mode of operation (Figure 1), all that must be done next is to wait for the return of the transmitted signal, traveling at approximately 0.9 milliseconds per foot out and back. The returning signal is amplified and appears as a high logic level echo output. The time between INIT going high and the Echo (ECHO) output going high is proportional to the distance of the target from the transducer. If desired, the cycle can now be repeated by returning INIT to a low logic level and then taking it high when the next transmission is desired.

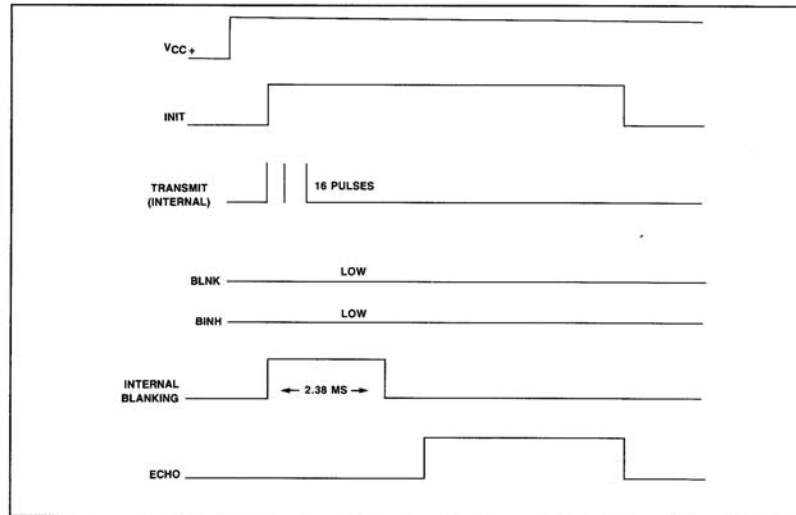

FIGURE 1: EXAMPLE OF A SINGLE-ECHO-MODE CYCLE WITHOUT BLANKING INPUT

If there is more than one target and a single transmission detects multiple echos, then the cycle is slightly different (Figure 2). After receiving the first return signal which causes the ECHO output to go high, the Blanking (BLNK) input must be taken high then back low to reset the ECHO output for the next return signal. The blanking signal must be at least 0.44 milliseconds in duration to account for all 16 returning pulses from the first target and allow for internal delay times. This corresponds to the two targets being 3 inches apart.

During a cycle starting with INIT going high, the receiver amplifier gain is increased at discrete times (Figure 3) since the transmitted signal is attenuated with distance. At approximately 38 milliseconds, the maximum gain is attained. Although gain can be increased by varying R1 (see Component Layout), there is a limit to which the gain can be increased for reliable module operation. This will vary from application to application. The modules are "kitted" prior to their final test during manufacture. This is necessary because the desired gain distribution is much narrower than the module gain distribution if all were kitted with one value resistor. As kitted, these modules will perform satisfactorily in most applications. As a rule of thumb, the gain can be increased up to a factor of 4, if required, by increasing R1 correspondingly. Gain is directly proportional to R1.

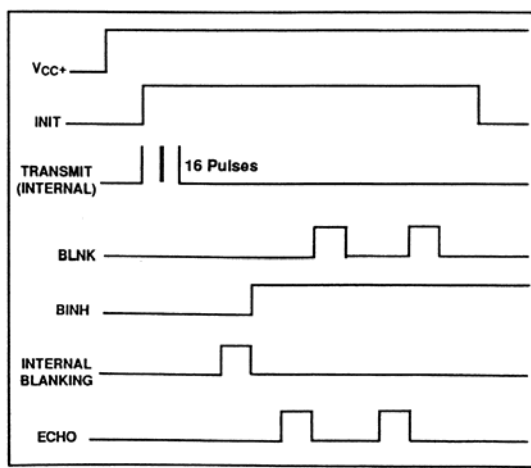

FIGURE 2: EXAMPLE OF A MULTIPLE-ECHO-MODE CYCLE WITH BLANKING INPUT

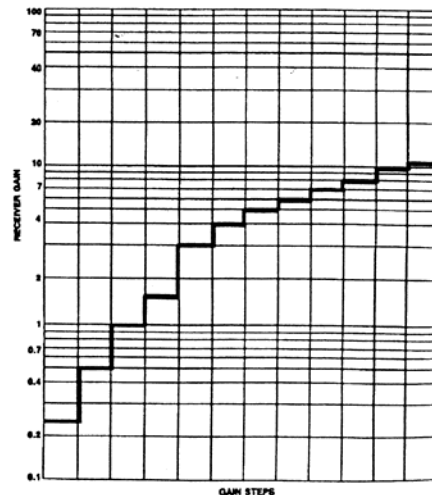

FIGURE 3: RECEIVER GAIN VS GAINSTEP NUMBERS

**Input/Output Schematic Notes:**

The ECHO and OSC outputs are open collector NPN transistor outputs (Figure 4) requiring 4.7 Kohm pull-up resistors between V<sub>CC</sub> and the output.

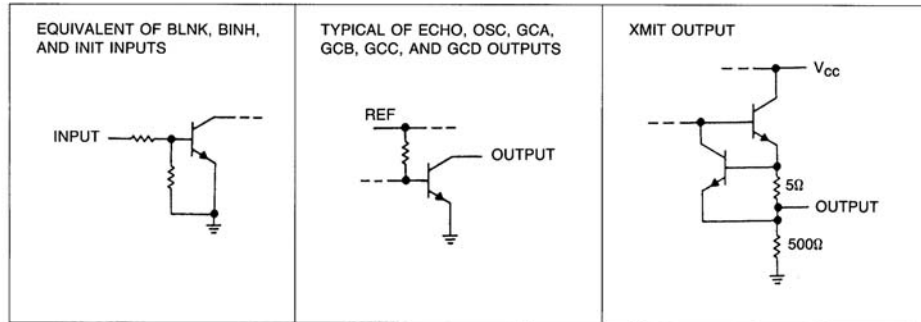
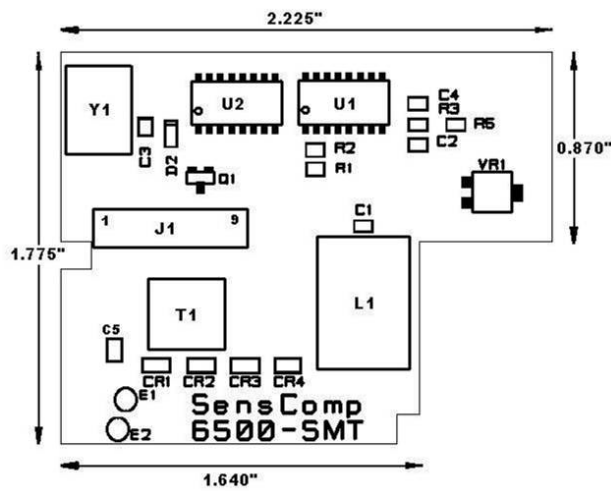
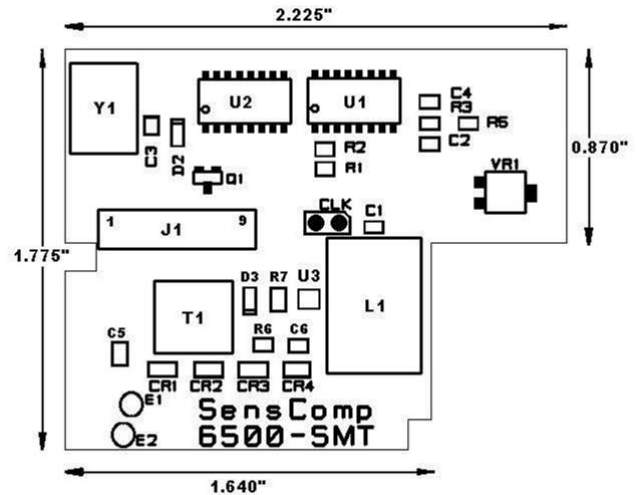

FIGURE 4: SCHEMATIC EQUIVALENT CIRCUITS OF BOARD INPUTS/OUTPUTS

**Component Layouts**



6500 SMT Ranging Module  
PID#615078



6500E Enhanced SMT Ranging Module  
PID#615079

Schematic – 6500 SMT Ranging Module--PID#615078

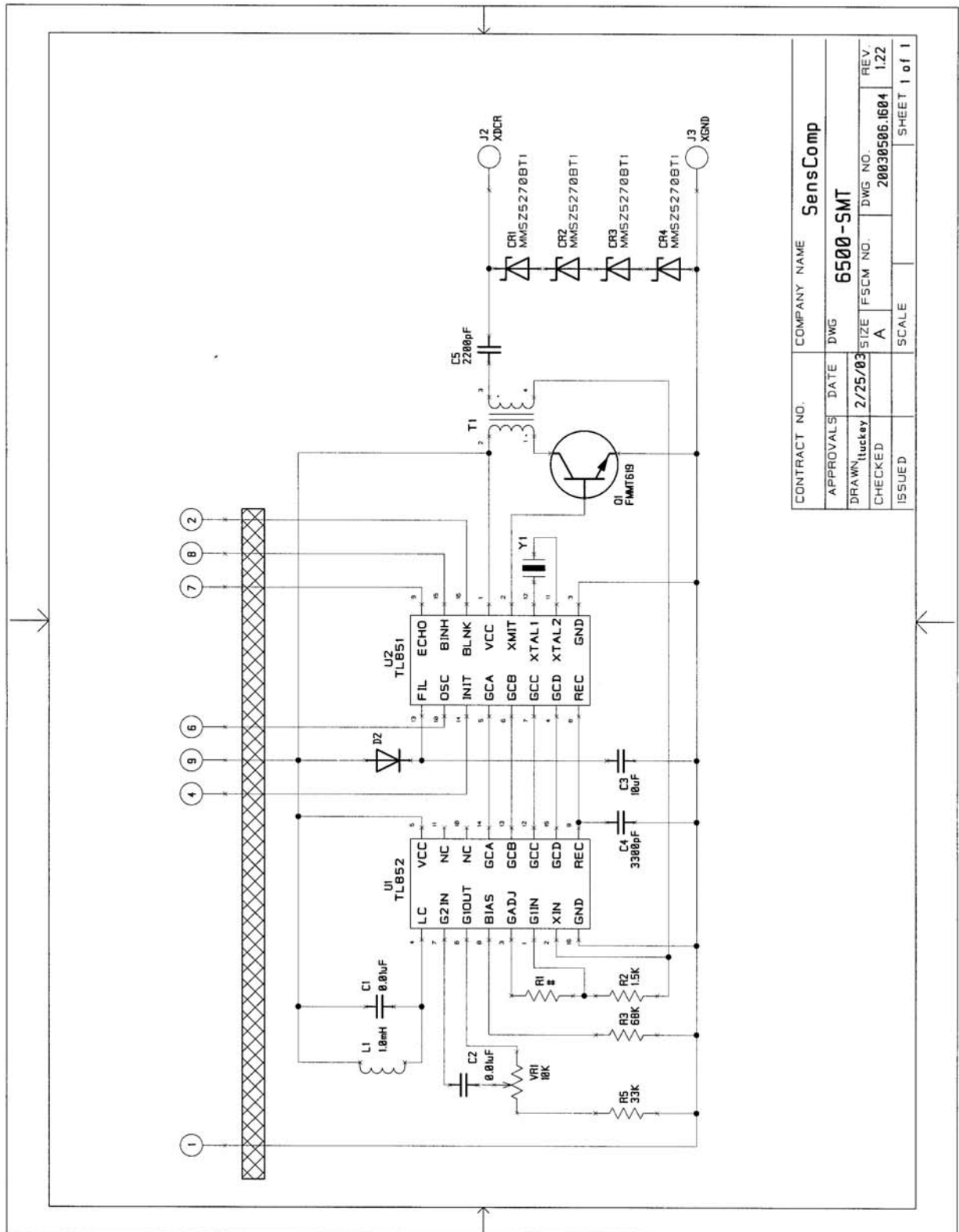

CONTRACT NO.		COMPANY NAME		SensComp	
APPROVALS	DATE	DWG	6500-SMT		
DRAWN	lucky	2/25/03	SIZE	FSCM NO.	DWG NO.
CHECKED			A	20030506.1604	1.22
ISSUED			SCALE		SHEET 1 of 1

Schematic – 6500E Enhanced SMT Ranging Module --PID#615079

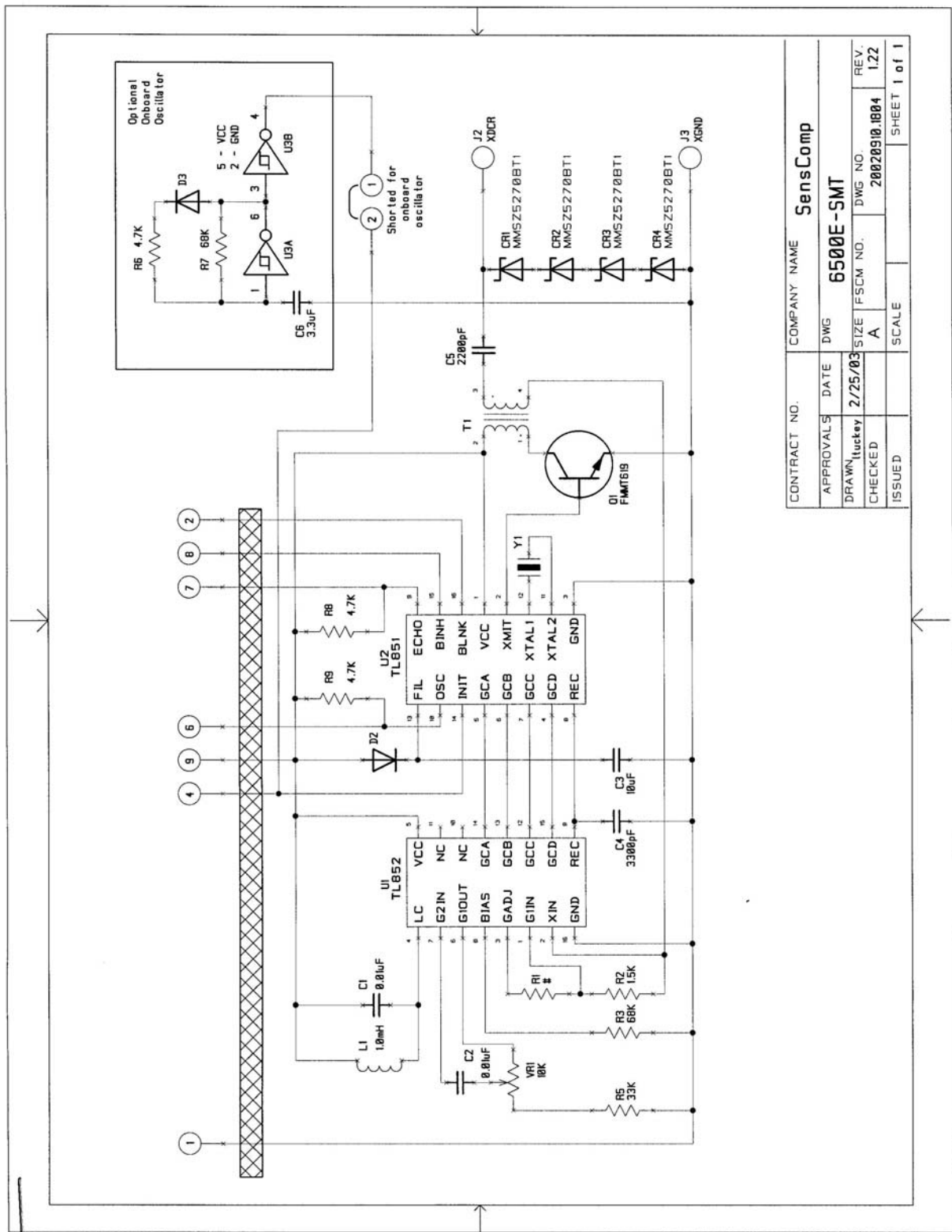

CONTRACT NO.		COMPANY NAME	
APPROVALS		DATE	
DRAWN		DWG	
CHECKED		SIZE	
ISSUED		SCALE	
		SHEET 1 of 1	
		REV.	
		REV. NO.	
		DWG NO.	
		FSCM NO.	
		20020910.1804	
		1.22	