

DOUBLE TRIODE

ECC83

High μ double triode, having separate cathodes, primarily intended for use as a resistance-coupled amplifier or phase inverter.

HEATER

Suitable for series or parallel operation, a.c. or d.c.

The heater is centre-tapped and the two sections may be operated in series or in parallel with one another.

Series

V_h applied between pins 4 and 5.

Parallel

V_h applied between pin 9 and pins 4 and 5 connected together.

	Series	Parallel	
V_h	12.6	6.3	V
I_h	0.15	0.3	A

CAPACITANCES

$C_{a'-k}$	0.46	$\mu\mu\text{F}$
$C_{a''-k''}$	0.34	$\mu\mu\text{F}$
* C_{g-k}	1.6	$\mu\mu\text{F}$
* C_{a-g}	1.7	$\mu\mu\text{F}$
$C_{a'-a''}$	< 1.2	$\mu\mu\text{F}$
$C_{a''-g'}$	< 0.1	$\mu\mu\text{F}$
$C_{a'-g''}$	< 0.1	$\mu\mu\text{F}$
$C_{g'-g''}$	< 0.01	$\mu\mu\text{F}$
* C_{g-h}	< 0.15	$\mu\mu\text{F}$

*Each section.

CHARACTERISTICS (each section)

V_a	100	250	V
I_a	0.5	1.2	mA
V_g	-1.0	-2.0	V
g_m	1.25	1.6	mA/V
μ	100	100	
r_a	80	62.5	k Ω

LIMITING VALUES (each section)

$V_{a(b)}$ max.	550	V
V_a max.	300	V
p_a max.	1.0	W
I_k max.	8.0	mA
$-V_g$ max.	50	V
* R_{g-k} max.	2.2	M Ω
V_{h-k} max.	180	V
† R_{h-k} max.	20	k Ω

*With grid current biasing R_{g-k} max. = 22 M Ω .

†When used as a phase inverter immediately preceding the output stage, R_{h-k} max. may be 120k Ω .



High μ double triode, having separate cathodes, primarily intended for use as a resistance-coupled amplifier or phase inverter.

OPERATING CONDITIONS AS RESISTANCE COUPLED A.F. ← AMPLIFIER (with cathode bias)

V_b (V)	R_a (k Ω)	I_k (mA)	R_k (Ω)	$\frac{V_{out}}{V_{in}}$	V_{out}^* (V _{r.m.s.})	D_{tot}^* (%)	R_{g1}^\dagger (k Ω)
400	47	2.45	680	44	37	3.6	150
350	47	1.98	820	42.5	33	4.4	150
300	47	1.55	1000	40	26	5.0	150
250	47	1.18	1200	37.5	23	7.0	150
200	47	0.86	1500	34	18	8.5	150
400	100	1.72	820	63	38	1.7	330
350	100	1.4	1000	61	36	2.2	330
300	100	1.11	1200	57	30	2.7	330
250	100	0.86	1500	54.5	26	3.9	330
200	100	0.65	1800	50	20	4.8	330
400	220	1.02	1200	76.5	38	1.1	680
350	220	0.85	1500	75.5	37	1.6	680
300	220	0.63	2200	72	36	2.6	680
250	220	0.48	2700	66.5	28	3.4	680
200	220	0.36	3300	56	24	4.6	680

* Output voltage and distortion at start of positive grid current. At lower output voltage the distortion is approximately proportional to the output voltage

† R_{g1} = grid resistance of following valve.

OPERATING CONDITIONS AS RESISTANCE COUPLED A.F. ← AMPLIFIER* (with grid current bias)

V_b (V)	R_a (k Ω)	I_k (mA)	$\frac{V_{out}}{V_{in}}$	V_{out} (V _{r.m.s.})	D_{tot} (%)	R_{g1}^\dagger (k Ω)
400	47	3.1	45	37	2.5	150
350	47	2.5	44	33	2.7	150
300	47	2.0	41	26	2.9	150
250	47	1.45	39	23	4.2	150
200	47	1.0	37	18	5.6	150
400	100	1.95	58	38	1.6	330
350	100	1.6	56	36	1.8	330
300	100	1.3	54	30	2.0	330
250	100	1.0	51	26	2.6	330
200	100	0.7	50	20	3.9	330
400	220	1.09	68	38	1.4	680
350	220	0.88	67	37	1.7	680
300	220	0.74	66	36	2.2	680
250	220	0.56	62	28	2.7	680
200	220	0.39	58	24	4.6	680

* Measured with a grid resistance of 10M Ω and signal source impedance $Z_s=100\Omega$.

† R_{g1} = grid resistance of following valve.

DOUBLE TRIODE

ECC83

High μ double triode, having separate cathodes, primarily intended for use as a resistance-coupled amplifier or phase inverter.

OPERATING CONDITIONS AS RESISTANCE COUPLED A.F.← AMPLIFIER* (with grid current bias)

V_b (V)	R_a (k Ω)	I_k (mA)	$\frac{V_{out}}{V_{in}}$	D_{tot} (%) for $V_{out(r.m.s.)}$			$R_{g1}\dagger$ (k Ω)
				=2V	=4V	=6V	
400	47	3.8	41	2.1	4.2	5.4	150
350	47	3.19	40	2.2	4.2	5.5	150
300	47	2.52	38	2.2	4.5	5.5	150
250	47	1.95	36	2.3	4.6	5.6	150
200	47	1.4	34	2.4	4.7	5.6	150
150	47	0.84	33	2.5	4.6	5.2	150
100	47	0.35	25	1.7	2.1	6.0	150
400	100	2.3	52	1.7	3.5	4.8	330
350	100	1.9	51	1.8	3.6	4.9	330
300	100	1.58	50	1.8	3.6	5.0	330
250	100	1.23	48	1.8	3.8	5.1	330
200	100	0.88	46	1.9	3.8	5.1	330
150	100	0.56	43	1.9	3.0	4.7	330
100	100	0.24	34	1.6	2.3	2.5	330
400	220	1.23	60	1.6	2.7	4.2	680
350	220	1.05	59	1.6	2.8	4.3	680
300	220	0.85	58	1.6	2.9	4.4	680
250	220	0.67	57	1.6	2.9	4.4	680
200	220	0.49	54	1.7	3.0	4.4	680
150	220	0.32	51	1.7	3.0	4.4	680
100	220	0.14	42	1.6	2.5	3.2	680

*Measured with a grid resistance of 10M Ω and signal source impedance $Z_g=330k\Omega$.

† R_{g1} =grid resistance of following valve.

ECC83

DOUBLE TRIODE

High μ double triode, having separate cathodes, primarily intended for use as a resistance-coupled amplifier or phase inverter.

TYPICAL OPERATING CONDITIONS AS A PHASE INVERTER

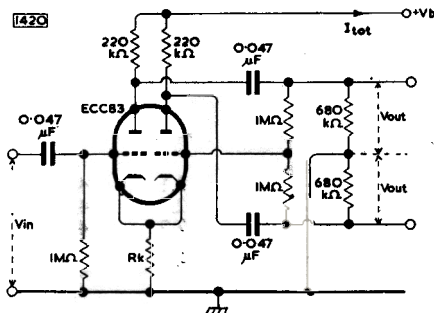

V_b (V)	I_{tot} (mA)	R_k (Ω)	V_{out}^* (V _{r.m.s.})	$\frac{V_{out}}{V_{in}}$	D_{tot}^* (%)
250	1.08	1200	35	58	5.5
250	1.08	1200	7	58	1.1
350	1.7	820	45	62	3.5
350	1.7	820	9	62	0.7

*Output voltage and distortion at the start of positive grid current. At lower output voltage the distortion is approximately proportional to the voltage.

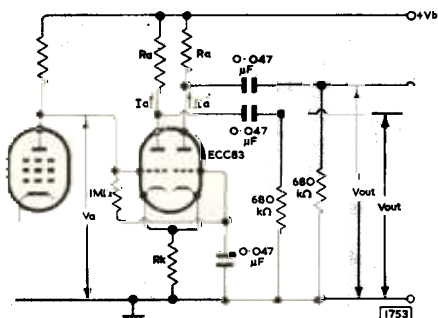

V_b (V)	$\dagger V_a$ (approx.) (V)	$I_a + I_{a'}$ (mA)	R_k (k Ω)	R_a (k Ω)	V_{out}^* (V _{r.m.s.})	$\frac{V_{out}}{V_{in}}$	D_{tot}^* (%)
250	65	1.0	68	100	20	25	1.8
250	65	1.0	68	100	7	25	0.6
350	90	1.2	82	150	35	27	1.8
350	90	1.2	82	150	10	27	0.5

*Output voltage and distortion at the start of positive grid current. At lower output voltage the distortion is approximately proportional to the voltage.

$\dagger V_a$ should be adjusted so that $I_a + I_{a'} = 1$ mA at $V_b = 250$ V and 1.2 mA at $V_b = 350$ V.



DOUBLE TRIODE

ECC83

High μ double triode, having separate cathodes, primarily intended for use as a resistance-coupled amplifier or phase inverter.

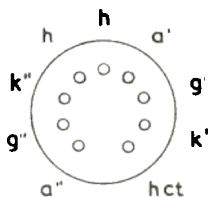
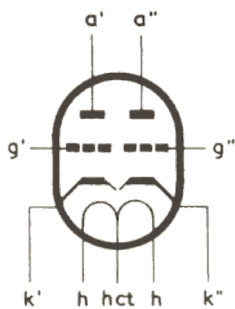

B9A
Noval Base

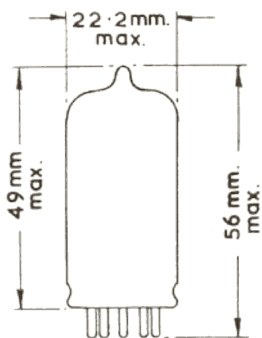

504

ECC83

DOUBLE TRIODE

High μ double triode, having separate cathodes, primarily intended for use as a resistance-coupled amplifier or phase inverter.

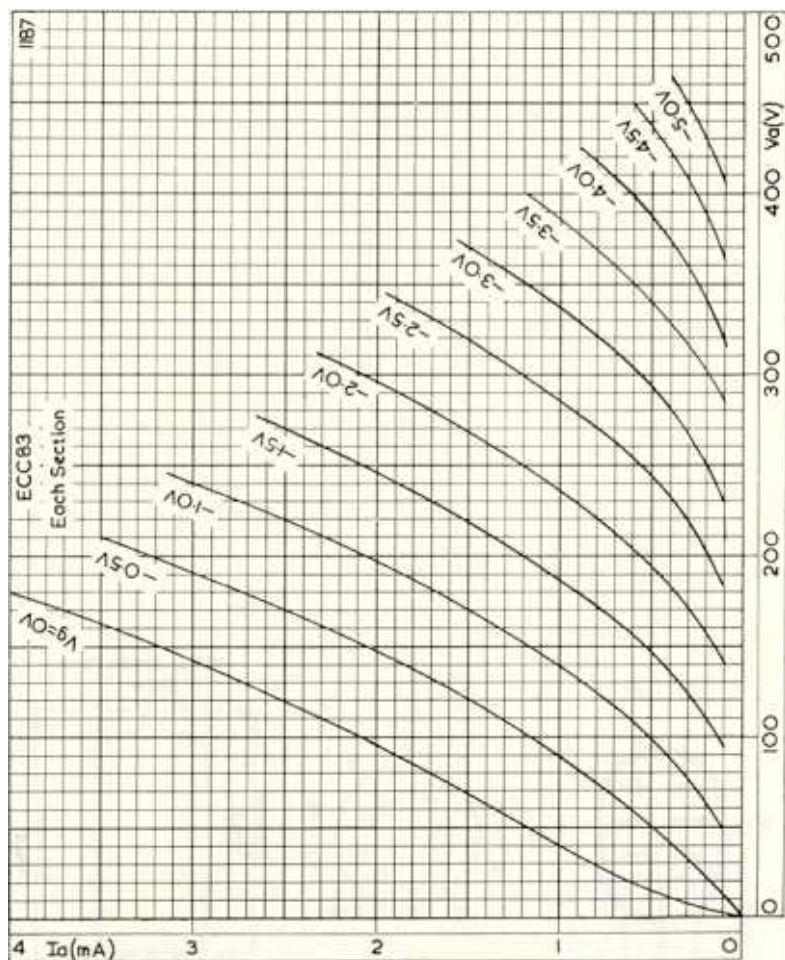

ANODE CURRENT PLOTTED AGAINST ANODE VOLTAGE, WITH GRID VOLTAGE AS PARAMETER (EACH SECTION)

DOUBLE TRIODE

ECC83

High μ double triode, having separate cathodes, primarily intended for use as a resistance-coupled amplifier or phase inverter.

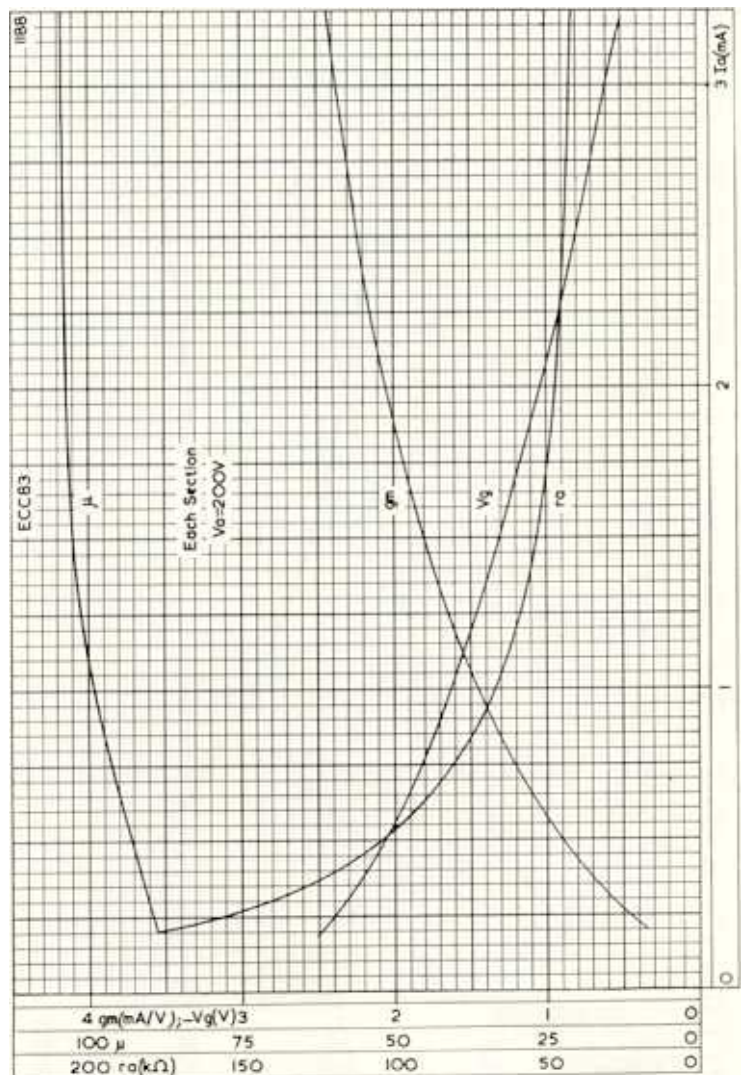

GRID VOLTAGE, MUTUAL CONDUCTANCE, AMPLIFICATION FACTOR AND INTERNAL RESISTANCE PLOTTED AGAINST ANODE CURRENT, FOR ANODE VOLTAGE OF 200 V (EACH SECTION)

ECC83

DOUBLE TRIODE

High μ double triode, having separate cathodes, primarily intended for use as a resistance-coupled amplifier or phase inverter.

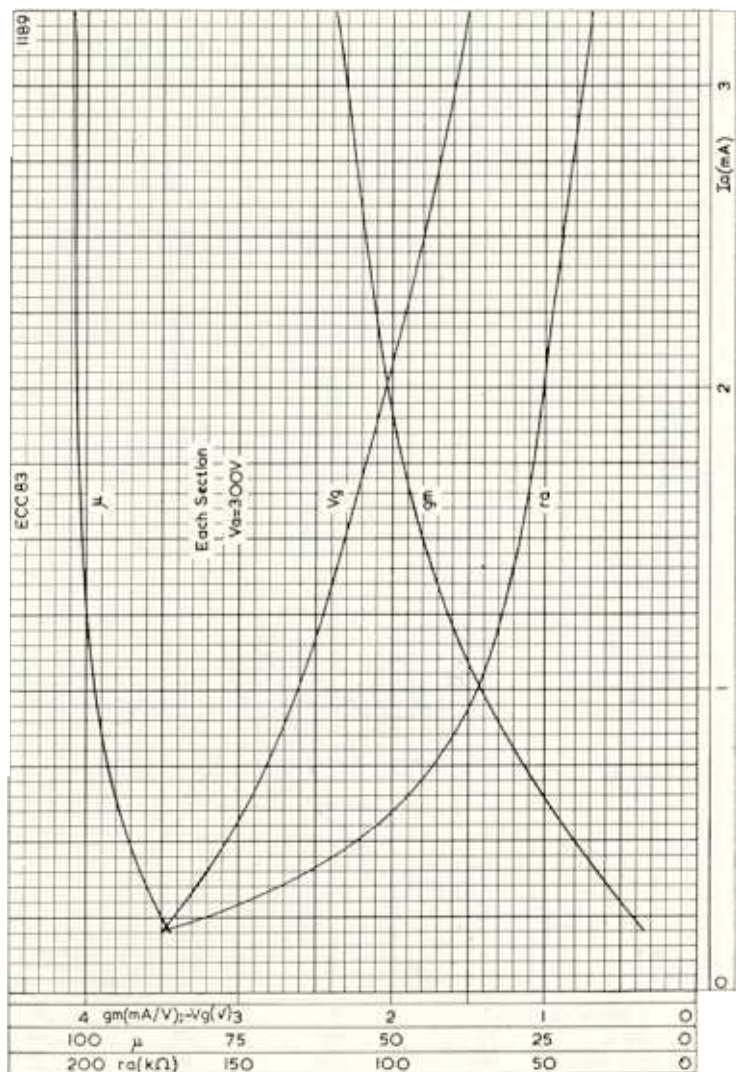

GRID VOLTAGE, MUTUAL CONDUCTANCE, AMPLIFICATION FACTOR AND INTERNAL RESISTANCE PLOTTED AGAINST ANODE CURRENT, FOR ANODE VOLTAGE OF 300 V (EACH SECTION)