

Coaxial

Power Splitter/Combiner

ZFSC-2-1W+

2 Way-0° 50Ω 1 to 750 MHz



Maximum Ratings

Operating Temperature	-55°C to 100°C
Storage Temperature	-55°C to 100°C
Power Input (as a splitter)	1W max.
Internal Dissipation	0.125W max.

Coaxial Connections

SUM PORT	3
PORT 1	1
PORT 2	2

Outline Drawing

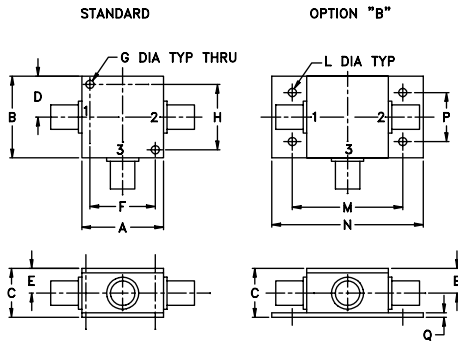

Outline Dimensions (inch/mm)

A	B	C	D	E	F	G	H	J	K	L	M	N	P	Q	wt
1.25	1.25	.75	.63	.38	1.00	.125	1.000	--	--	.125	1.688	2.18	.75	.07	grams
31.75	31.75	19.05	16.00	9.65	25.40	3.18	25.40	--	--	3.18	42.88	55.37	19.05	1.78	70.0

For option B with N-type connectors, dimension "C" increases to 0.94 inches.

Features

- low insertion loss, 0.4 dB typ.
- high isolation, 28 dB typ.
- excellent amplitude unbalance, 0.1 dB typ.
- excellent phase unbalance, 0.5 deg. typ.
- very good return loss, VSWR, 1.15:1 typ.
- rugged shielded case

Applications

- VHF/UHF
- federal & defense communication

BNC version shown
CASE STYLE: K18

Connectors	Model	Price	Qty.
BNC	ZFSC-2-1W+	\$48.95	(1-9)
SMA	ZFSC-2-1W-S+	\$53.95	(1-9)
N-TYPE	ZFSC-2-1W-N+	\$53.95	(1-9)
BRACKET (OPTION "B")		\$2.50	(1+)

+ RoHS compliant in accordance with EU Directive (2002/95/EC)

The +Suffix has been added in order to identify RoHS Compliance. See our web site for RoHS Compliance methodologies and qualifications.

Electrical Specifications

FREQ. RANGE (MHz)	ISOLATION (dB)						INSERTION LOSS (dB) ABOVE 3.0 dB						PHASE UNBALANCE (Degrees)			AMPLITUDE UNBALANCE (dB)		
	L		M		U		L		M		U		L	M	U	L	M	U
1-750	Typ.	Min.	Typ.	Min.	Typ.	Min.	Typ.	Max.	Typ.	Max.	Typ.	Max.	Max.	Max.	Max.	Max.	Max.	Max.
	30	20	28	20	25	20	0.2	0.5	0.4	0.8	0.8	1.0	2	4	4	0.15	0.15	0.30

L = low range [f_L to $10 f_L$] M = mid range [$10 f_L$ to $f_U/2$] U = upper range [$f_U/2$ to f_U]

Typical Performance Data

Frequency (MHz)	Insertion Loss (dB)		Amplitude Unbalance (dB)	Isolation (dB)	Phase Unbalance (deg.)	VSWR S	VSWR 1	VSWR 2
	S-1	S-2						
1.00	3.27	3.27	0.00	31.01	0.01	1.10	1.22	1.21
5.00	3.17	3.16	0.01	38.19	0.02	1.08	1.17	1.16
10.00	3.16	3.16	0.00	38.65	0.14	1.08	1.16	1.16
68.00	3.19	3.19	0.01	26.38	0.07	1.12	1.14	1.14
97.00	3.23	3.23	0.00	25.75	0.09	1.13	1.15	1.15
184.00	3.28	3.28	0.01	25.18	0.09	1.16	1.16	1.15
271.00	3.33	3.31	0.02	24.97	0.20	1.17	1.16	1.16
380.00	3.38	3.35	0.03	24.99	0.24	1.18	1.18	1.17
395.00	3.30	3.28	0.02	24.95	0.21	1.20	1.20	1.19
460.00	3.39	3.36	0.03	25.18	0.22	1.16	1.18	1.17
550.00	3.41	3.36	0.05	25.42	0.31	1.13	1.16	1.14
640.00	3.49	3.43	0.06	25.07	0.36	1.09	1.13	1.11
710.00	3.55	3.48	0.07	23.78	0.48	1.09	1.12	1.11
730.00	3.65	3.58	0.07	23.32	0.59	1.09	1.14	1.12
750.00	3.67	3.61	0.07	22.79	0.58	1.07	1.13	1.11

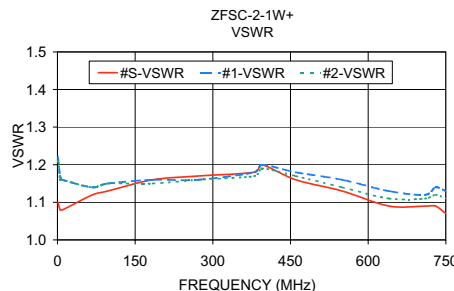
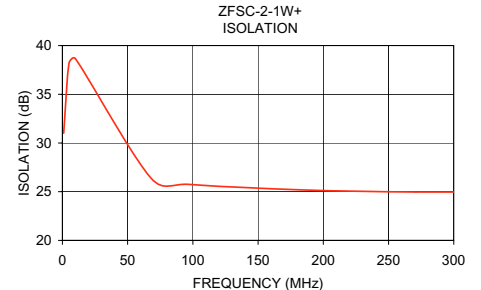
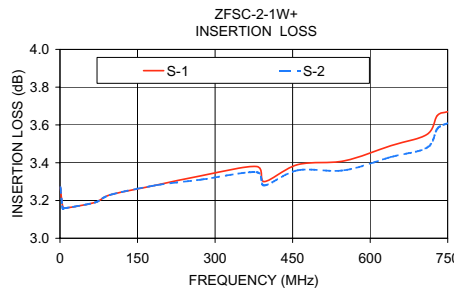

electrical schematic

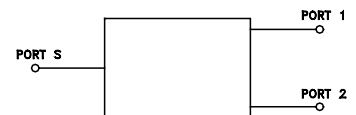

Mini-Circuits
ISO 9001 ISO 14001 CERTIFIED

ALL NEW
minicircuits.com

P.O. Box 350166, Brooklyn, New York 11235-0003 (718) 934-4500 Fax (718) 332-4661 For detailed performance specs & shopping online see Mini-Circuits web site



The Design Engineers Search Engine Provides ACTUAL Data Instantly From MINI-CIRCUITS At: www.minicircuits.com

RF/IF MICROWAVE COMPONENTS

REV. A
M108294
ZFSC-2-1W+
HY/TD/CP
070319